

# Single phase power-sensor

## 1-phase power-sensor, current transformer

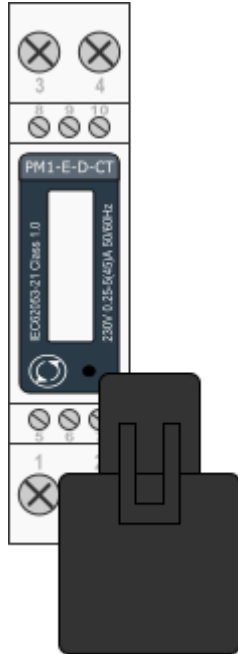

Model number:	<b>PM1-E-D-CT</b>
Connect to:	<b>MC-230</b> RS485 power sensor bus A - B
Mounting:	DIN rail, 1M, 18 mm
Dimensions:	18 × 62 × 119 mm
<b>Used for measuring power and energy of</b>	
✓	single-phase energy sources
✓	single-phase energy consumers

## Applications

- Digital multi-function power sensor for single phase networks

## Features

- DIN rail mounting with 50A current transformer
- Compact design in a single module 18mm wide
- Seal-able cover(phase and neutral terminals)

## General description

The PM1-E-D series is an advanced single phase energy monitoring solution with built-in configuration push button and LCD data displaying, particularly indicated for active energy and other parameters metering and for cost allocation. Housing for DIN-rail mounting, IP51 protection degree, direct connection up to max 45A.

## Technical specifications

Technical Data	
Operating Humidity	≤ 75%

Storage Humidity	≤ 95%
Operating Temperature	-20°C - +50°C
Storage Temperature	-30°C - +70°C
International Standard	IEC 62053-21
Accuracy	Class 1
Mounting	DIN rail (DIN 43880)
Sealing	IP51 Indoor
Nominal Voltage Input	(Ph+N) 230V AC (176-276V AC)
Max Continuous Voltage	120% of nominal
AC Voltage Withstand	4KV for 1 minute
Impulse Voltage Withstand	6KV-1.2μS
Current Input	0.25-5A(6)A AC RMS
Operational Current Range	0.4% Ib-I <sub>max</sub>
Over current withstand	20I <sub>max</sub> for 0.01s
Nominal Input Current Burden	0.5VA
Frequency	50Hz(±10%)
Power Consumption	≤ 2W/10VA/phase
<b>Accuracy</b>	
Voltage, Current	0.5%
Frequency	0.2% of Mid-Frequency
Power Factor	1% of Unity (0.01)
Active Power, Apparent Power	≤ 1% of Range Maximum
Reactive Power	≤ 1% of Range Maximum
Reactive Energy (Varh)	Class 2
Active Energy (Wh)	Class 1
<b>Modbus</b>	
Bus Type	RS485 (Semi-Duplex)
Protocol	Modbus RTU
Baud Rate	1200/2400/4800/9600bps
Address Range	1-247
Max. Bus Loading	64pcs
Communication Distance	1000 Meters
Parity	EVEN/ODD/NONE
Data Bit	8
Stop Bit	1

# SDM120 Terminals

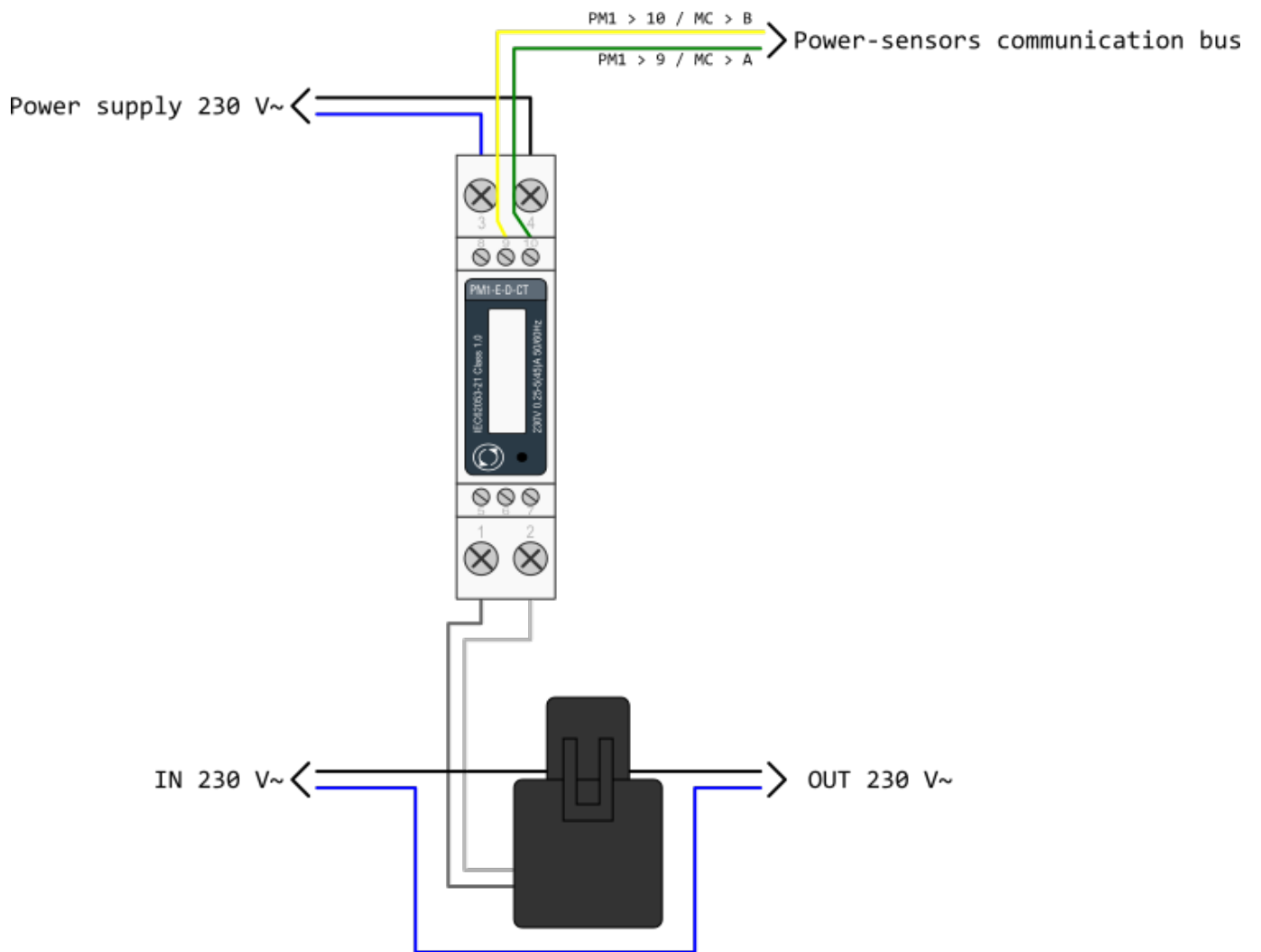

sdm120ct\_series\_datasheet.pdf  
sdm120ct\_protocol.pdf

From:  
<http://wiki.hiq-universe.com/> -

Permanent link:  
[http://wiki.hiq-universe.com/doku.php?id=en:hiq\\_hw:pm1-e-d-ct&rev=1563956176](http://wiki.hiq-universe.com/doku.php?id=en:hiq_hw:pm1-e-d-ct&rev=1563956176)

Last update: **2019/07/24 08:16**

