

# Three phase power sensor

## 3-phase power-sensor



Model number:	<b>PM3-E-D</b>
Connect to:	<b>MC-230</b> RS485 power sensor bus A - B
Mounting:	DIN rail, 1M, 18 mm
Dimensions:	66 × 72 × 100 mm
<b>Used for measuring power and energy of</b>	
✓	single/three-phase energy sources
✓	single/three-phase energy consumers

## Applications

- Digital multi-function power sensor for single/three phase networks

## Features

- DIN rail mounting
- Three Phase 100A Direct Fed
- Accuracy Class 0.5 (Active Energy)
- Bi-directional Measurement for kW and kWh
- Configurable Pulsed output (Import/ Export/Nett kWh)
- Line Frequency
- Power, maximum power demand and power factor
- Active energy imported and exported
- Reactive energy imported and exported
- Supported Modbus (SDM630Modbus)

## General description

SDM630 series measures and displays the characteristics of 1p2w, 3p3w and 3p4w supplies, including voltage, frequency, current, power, active and reactive energy, imported or exported, harmonic etc. Bi-directional measurement makes it an ideal choice for Solar PV measurement. The units support

Max. 100A direct connection, saving the cost and avoiding the trouble to connect external CTs. Two pulse outputs and 1 communication port (Mbus/Modbus) are provided for remote monitoring. The unit has been approved to meet the requirements of EU Directive 2014/32/EU.

## Technical specifications

<b>Technical Data</b>	
Operating Humidity	≤ 90%
Storage Humidity	≤ 95%
Operating Temperature	-25°C - +50°C
Storage Temperature	-40°C - +70°C
Mounting	DIN rail (DIN 43880)
Sealing	IP51 Indoor
Frequency	50Hz or 60Hz
Power Consumption	≤ 10W
<b>Accuracy</b>	
Voltage, Current	0.5%
Frequency	0.2% of Mid-Frequency
Power Factor	1% of Unity (0.01)
Active Power, Apparent Power	± 1% of Range Maximum
Reactive Power	± 1% of Range Maximum
Reactive Energy (Varh)	± 1% of Range Maximum
Active Energy (Wh)	Class 1 IEC 62053-21
<b>Current transformer</b>	
Frequency	50-60 Hz
Rated current	50 A
Accuracy	from 20% to 120% of rated current
Phase angle	less than 2 degrees at 50% of rated current
Insulation voltage	600 VAC
Maximum primary voltage	5000 VAC (insulated conductor)
Dielectric strength	2.5 kV/1mA/1min
Operating temperature	-15 to 60°C
Operating humidity	< 85 %
Case material	PC/UL94-V0
Bobin	PBT
Core	Permalloy
Internal structure	Epoxy
Leads	UL 1015, Twisted pair, 22 AWG
<b>Modbus</b>	
Bus Type	RS485 (Semi-Duplex)
Protocol	Modbus RTU
Baud Rate	1200/2400/4800/9600bps
Address Range	1-247
Max. Bus Loading	64pcs
Communication Distance	1000 Meters
Parity	EVEN/ODD/NONE

Data Bit	8
Stop Bit	1

## Dimensions

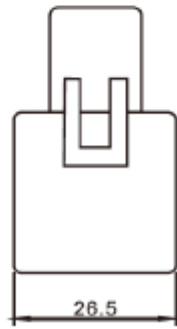
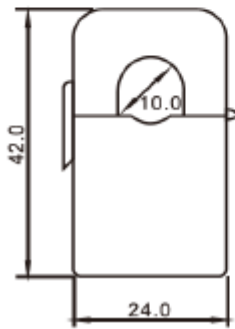
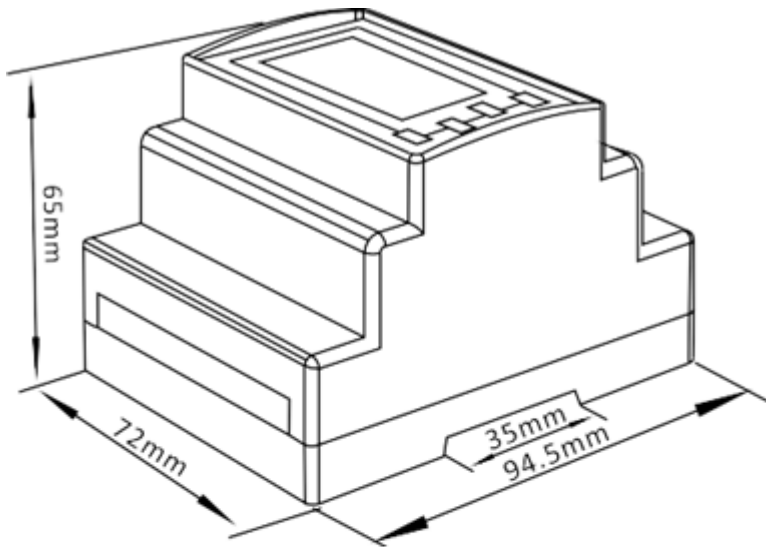

## Installation

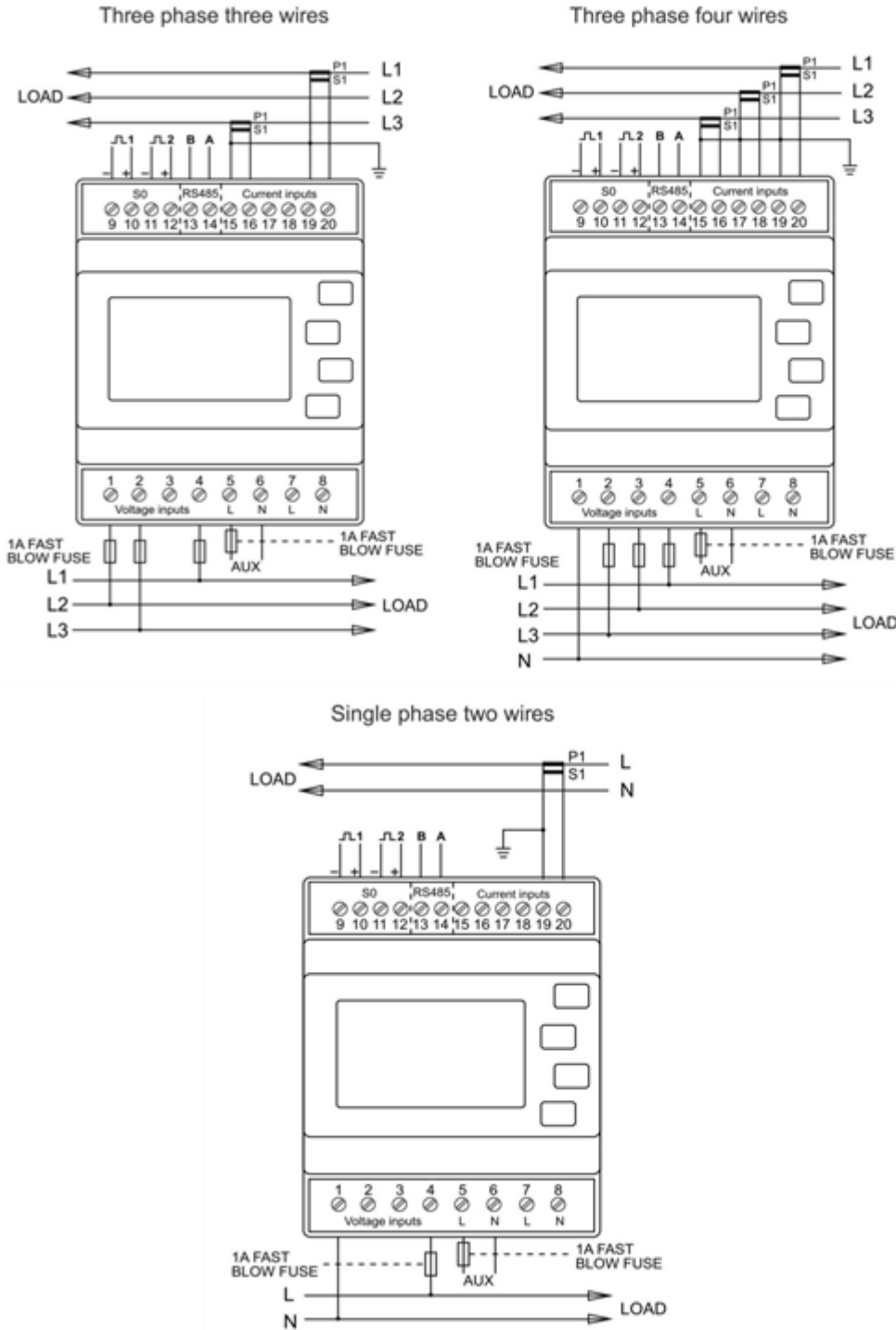

hiq\_pm3-e-d-ct\_user\_manual\_v1.pdf  
hiq\_pm3-e-d-ct\_protocol\_v1.6.pdf

From:  
<https://wiki.hiq-universe.com/> -

Permanent link:  
[https://wiki.hiq-universe.com/doku.php?id=en:hiq\\_hw:pm3-e-d&rev=1669800309](https://wiki.hiq-universe.com/doku.php?id=en:hiq_hw:pm3-e-d&rev=1669800309)

Last update: 2022/11/30 09:25

