

Wireless Modbus-to-Modbus bridge

Wireless Modbus-to-Modbus bridge





Model number:	WM-1
Frequency:	ISM 868MHz (EU)
Dimensions:	93x45x27 mm

Applications

- Replacement for RS485 wiring solution with wireless. Optimal for long range Modbus RTU serial communications with half duplex configuration.

Installation and mounting

-  Carefully open WM-1 module and configure serial communication with jumpers. (Default configuration is 9600bps, 8N1 with normal timeout)
-  Place WM-1 module at least 10cm from other objects. Installation is not recommended inside metal cabinets.
- Connect RS485 terminals to WM-1 RS485 terminals
 - A - A
 - B - B
 - C - GND
- Connect to 230V power supply
- Configure radio pairing



Features

- replacement for RS485 wiring
- Modbus RTU serial protocol
- wired/wireless combinations
- very long range, no hopping
- protected private connection
- multiple slaves per device
- multiple addressable groups

Technical specification

Power supply:	230V, 50/60Hz, 1W
Ingress protection:	IP20
Operating temperature:	-20..50°C
Storage temperature:	-40..85°C
Relative humidity:	0..85% n/c

Terminals and wiring

To power sensor	A	RS485 bus
	B	
	C	
To power supply	L	230V AC
	N	

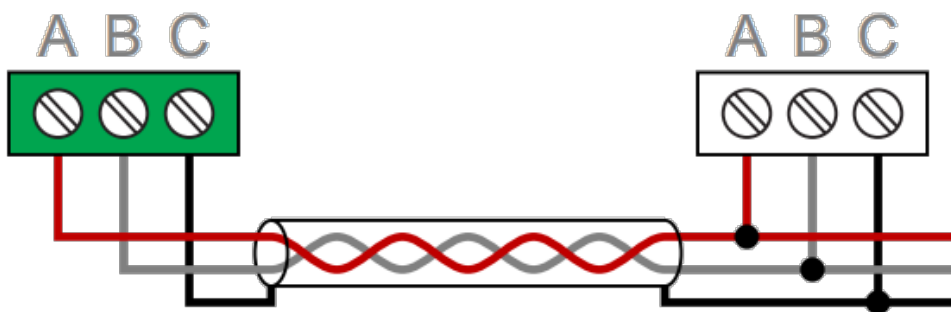

Radio configuration

Create new secure group

- * turn on all devices as the same time
- * within 10 seconds, while RF LED is blinking, press and hold button on one of the devices
- * after a second, the new address is randomly generated and sent to all devices. RF LED will blink 3 times to confirm the new address.

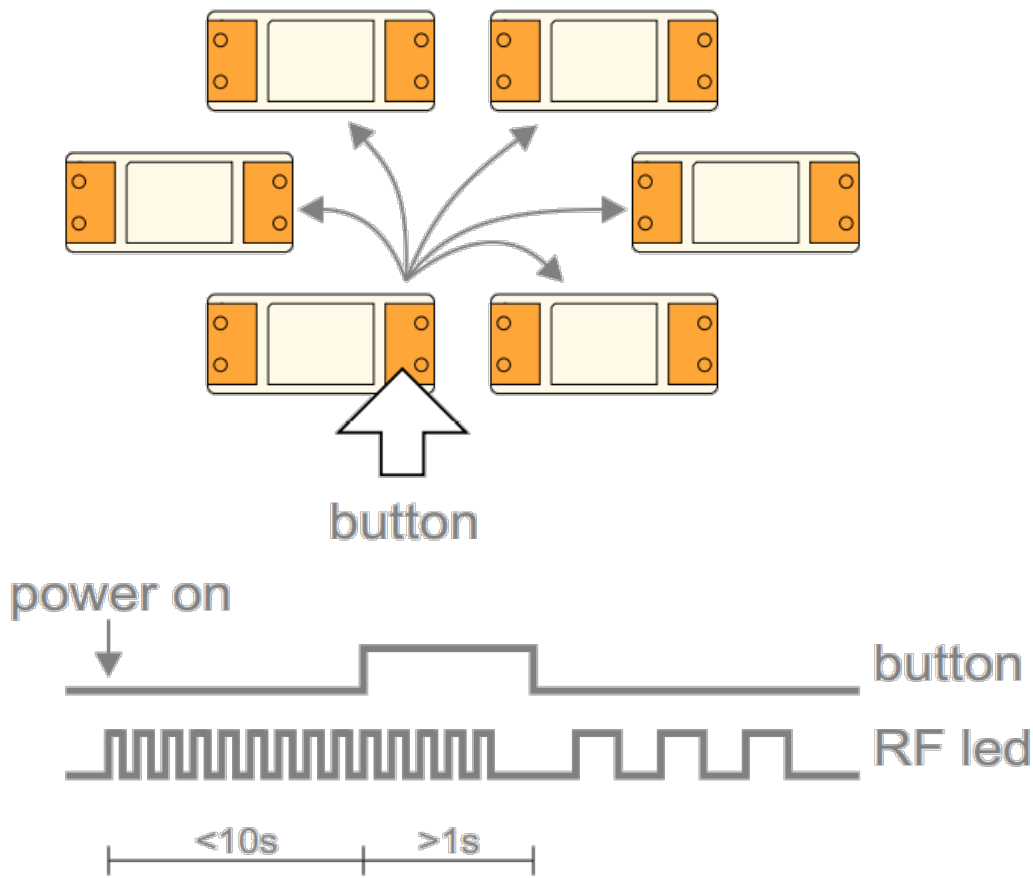

Add new device to the group

- * turn on the device
- * within 10 seconds, press and hold button on one of the existing devices
- * after a second, the existing group address is sent to the new device. RF LED will blink 3 times to confirm the address is sent.

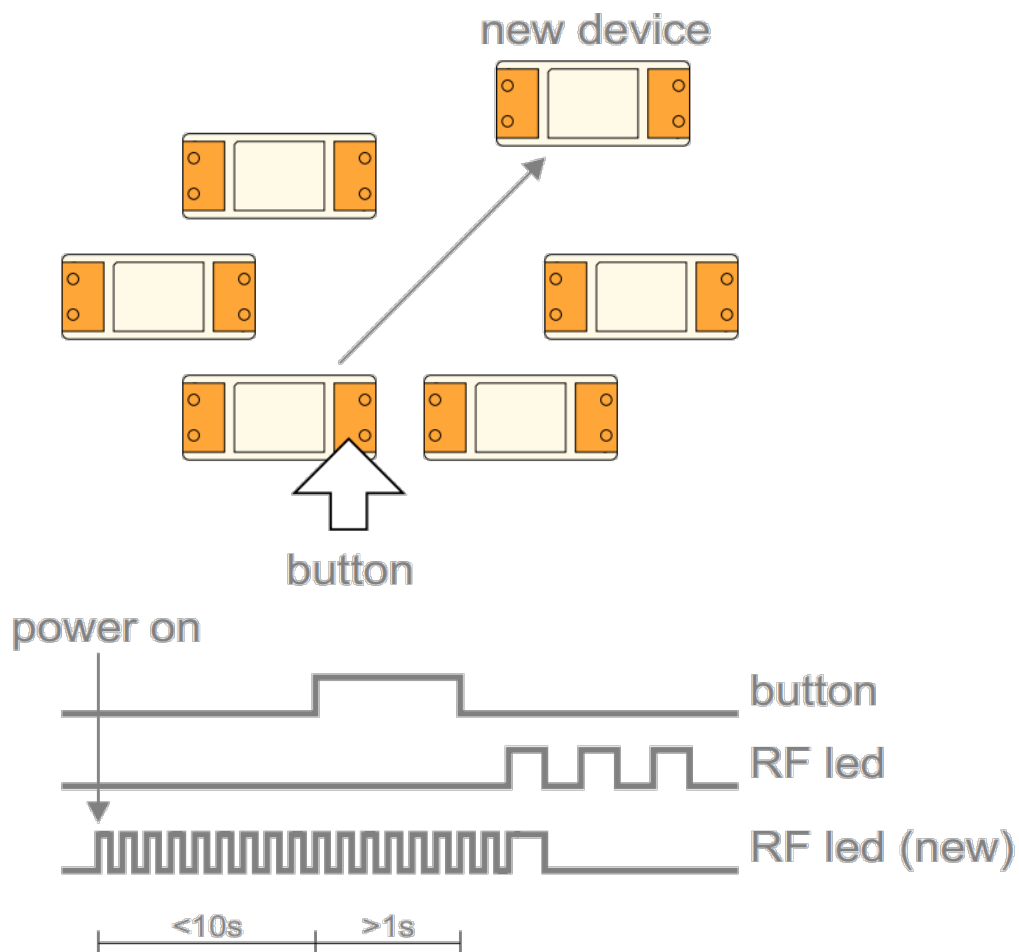

Topology examples

- * Modbus master, connected to 12 slaves using a pair of WM-1 devices
- * Modbus master, connected to 10 slaves, organized in two groups
- * Modbus master, connected to 5 slaves, each one having local WM-1 device

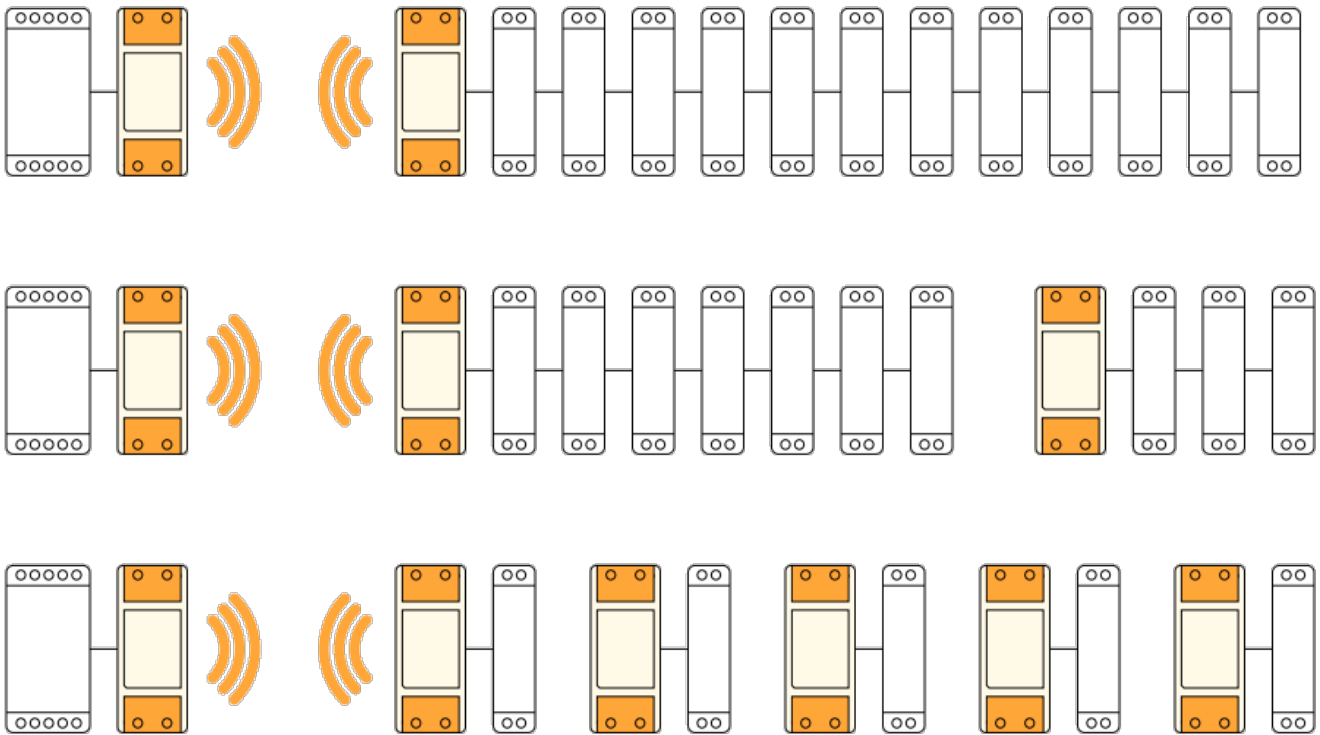

Multiple groups

* When the system has two or more separate Modbus lines, they should be configured as separate groups. Each group has a single master and one or more slaves.

* Groups can't talk to each other, but they share the same bandwidth. Two masters may start transmitting at the same time causing collisions. To reduce number of missed messages, keep the traffic low.

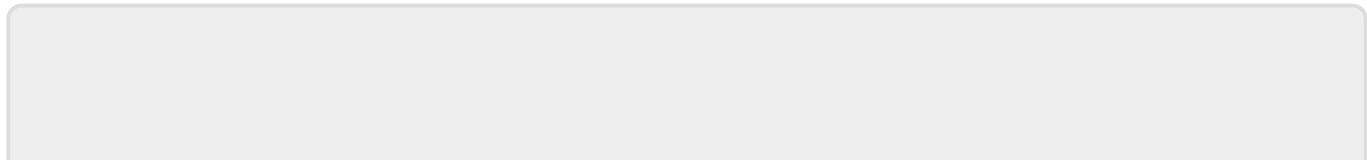
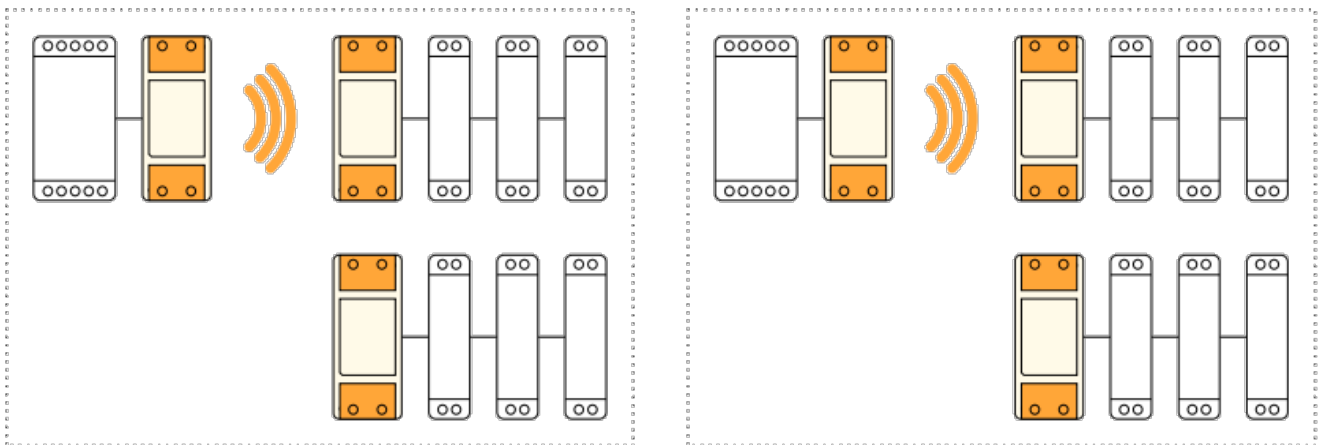

From:

<https://wiki.hiq-universe.com/> -

Permanent link:

https://wiki.hiq-universe.com/doku.php?id=en:hiq_hw:wm-1&rev=1634806674



Last update: **2021/10/21 08:57**