

# Light controller

## 8 relay outputs with parallel option

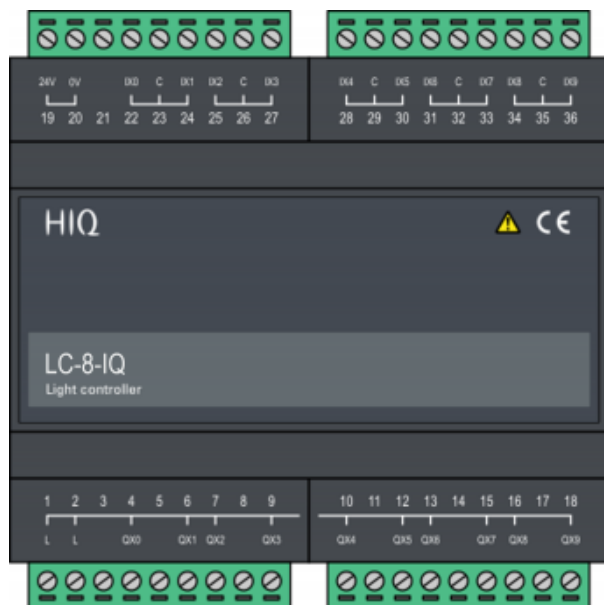

Model number:	<b>LC-8-IQ</b>
Mounting:	DIN rail, 6M, 106 mm
Dimensions:	106×108×58 mm

## Applications

- general purpose discrete (ON/OFF) lights
- common and NO terminal on each relay individually
- automatic corridor and stairs lights
- door-bell
- managed sockets
- bathroom and other single speed fans
- managed appliances (boiler, oven, electric cooker, ...)

## Features

- Configurable output:
  - Normal mode - general purpose light; input toggles light
  - Timer (auto off) mode - transitional lights; often used in combination with a presence sensor
- Configurable input:
  - Normal (toggle push-button)
  - Timer reload (extended time for staircase lighting)
  - Momentary (output is active while input is pressed - used for doorbell)
  - Presence or door sensor (sensor activates light, use timer mode for auto off)
  - Scene set (no direct light action)
- Smart restart after power supply interruption
- Stand alone / HIQ expansion
- PC, smartphone and cloud connectivity

## General description

The discrete light controller LC-8-IQ is HIQ intelligent expansion module primarily used for controlling discrete (non-dimmable) lights. Featuring high power relay output, it can control other consumers too (mains sockets, heaters, fans,..). Module can be used as stand-alone or part of the integrated system, when connected to one of HIQ Home Controller. Many features are available in the stand alone mode, while advanced features like scenes, scheduling, smartphone operation, internet connection are only available when connected to the appropriate Home Controller.

## Technical specification

Output power per relay	
- incandescent / halogen 230V	800 W
- halogen 12 V with transformer	400 W
- fluorescent with electronic ballast	400 W
- parallel compensated fluo lamps	250 W / 30 uF
- electric heater	1400 W
Total output power (all relays):	4000 W
Nominal output current:	10 A
Nominal current for parallel outputs:	10 A
Inputs	internal pull-up, 12 V, 2 mA
Maximum input cable length:	50 m
Power supply:	24 V / max. 145 mA
Ingress protection:	IP20
Operating temperature:	0..45 °C
Storage temperature:	-20..75 °C
Relative humidity:	0..95 % n/c

## Terminals

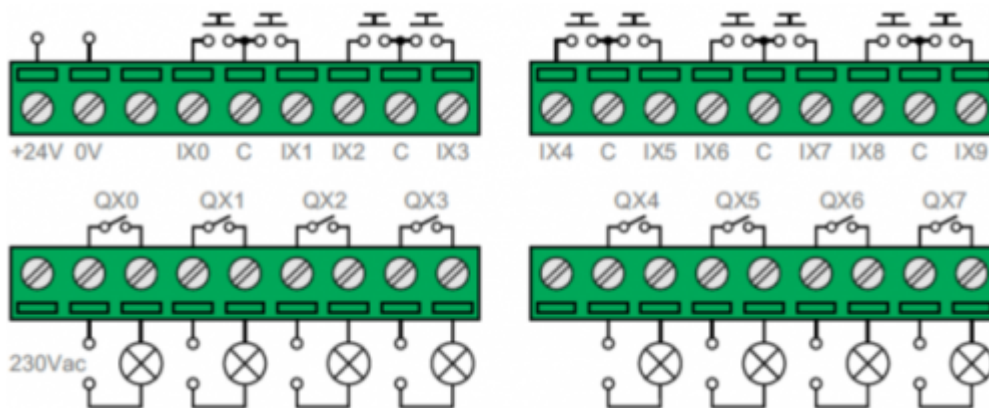

## Modes

### Input mode



Input mode define how an input affect the output. Toggle, staircase, doorbell, motion and door sensor are handled internally. Scene and ready light are handled by master controller.

### Output mode

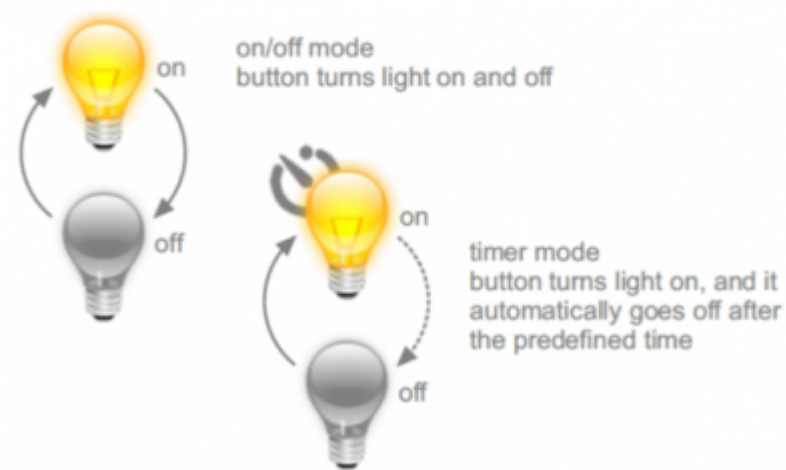

### Parallel outputs

For a maximum output power, two outputs can be connected in parallel. Fully synchronous operation is ensured by firmware.

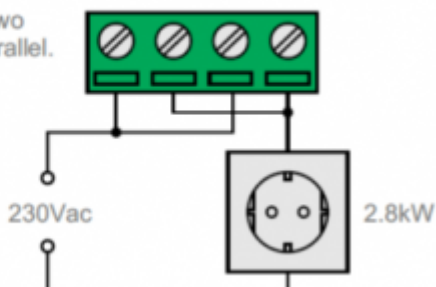

From:

<http://wiki.hiq-universe.com/> -

Permanent link:

[http://wiki.hiq-universe.com/doku.php?id=en:ms\\_main:lc-8-iq&rev=1587363017](http://wiki.hiq-universe.com/doku.php?id=en:ms_main:lc-8-iq&rev=1587363017)



Last update: **2020/04/20 06:10**