

# Robotina Battery Management System

## General description

This system comprehensively measures the battery performance, and displays the real-time parameters and real-time alarm for the failed battery to realize the automation of battery detection and failure expected detection. Through real-time monitoring of the battery power parameters and operating status obtained by the Controller, the actual operating status and health status of the battery pack can be accurately grasped, and problems existing in the use of the battery pack can be found in time. The HMI touch display displays the power data, health status and alarm reminder of each battery in real time. The cell sensors detects the condition of each battery in real time, and gives a timely alarm to the bad battery, so as to accurately grasp the actual running state and health of the battery pack in real time, and to timely find problems in the use of the battery pack. This not only effectively extends the backup time and operating life of the battery pack, but also greatly reduces the maintenance costs such as manpower and material resources. It also improves the safety of battery use, reduces the accident rate and effectively saves energy and reduces emissions, creating for the user and create good economic and social benefits for the users.

## System diagram

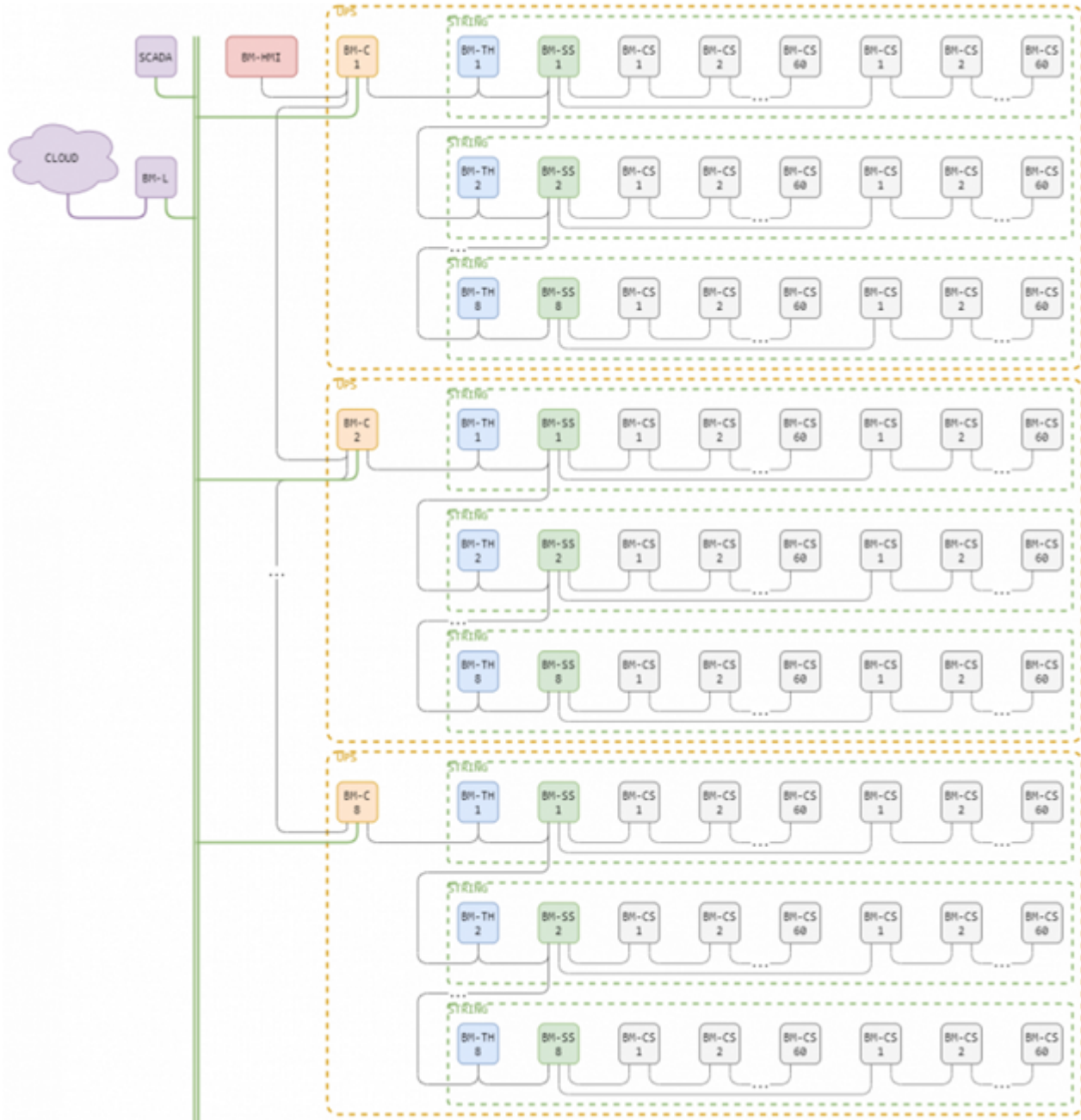

## Dictionary of terms and abbreviations

<b>BTMS</b>	Battery Management System	Battery monitoring system for larger UPS systems.
<b>battery</b>	-	Lead-acid rechargeable battery stores electricity to operate the UPS during a power outage.
<b>cell</b>	-	Basic battery building. A battery usually consists of several cells connected in series.
<b>string</b>	-	Multiple batteries connected in series.
<b>UPS</b>	Uninterruptible Power Supply	A device that provides battery backup when the electrical power fails or drops to an unacceptable voltage level.
<b>BM-CS</b>	Battery Cell Sensor	Sensor that monitors the status of an individual cell or battery.
<b>BM-SS</b>	Battery String Master	A sensor that connects the BM-CS and monitors the state of the string.

<b>BM-HS</b>	Hall Sensor	Direct current sensor that operates on the basis of the Hall effect.
<b>BM-TH</b>	Temperature and Humidity Sensor	Measurement of ambient temperature and relative humidity.
<b>BM-C</b>	Master Controller	A controller that allows monitoring the status of several BSMs, displaying the status of batteries and strings on the TD and serving data to the control system.
<b>BM-HMI</b>	Touch Display	Graphic display with touch screen.
<b>BM-L</b>	IOT Linker	Enables secure connection to the online cloud service.

## Wiring diagram

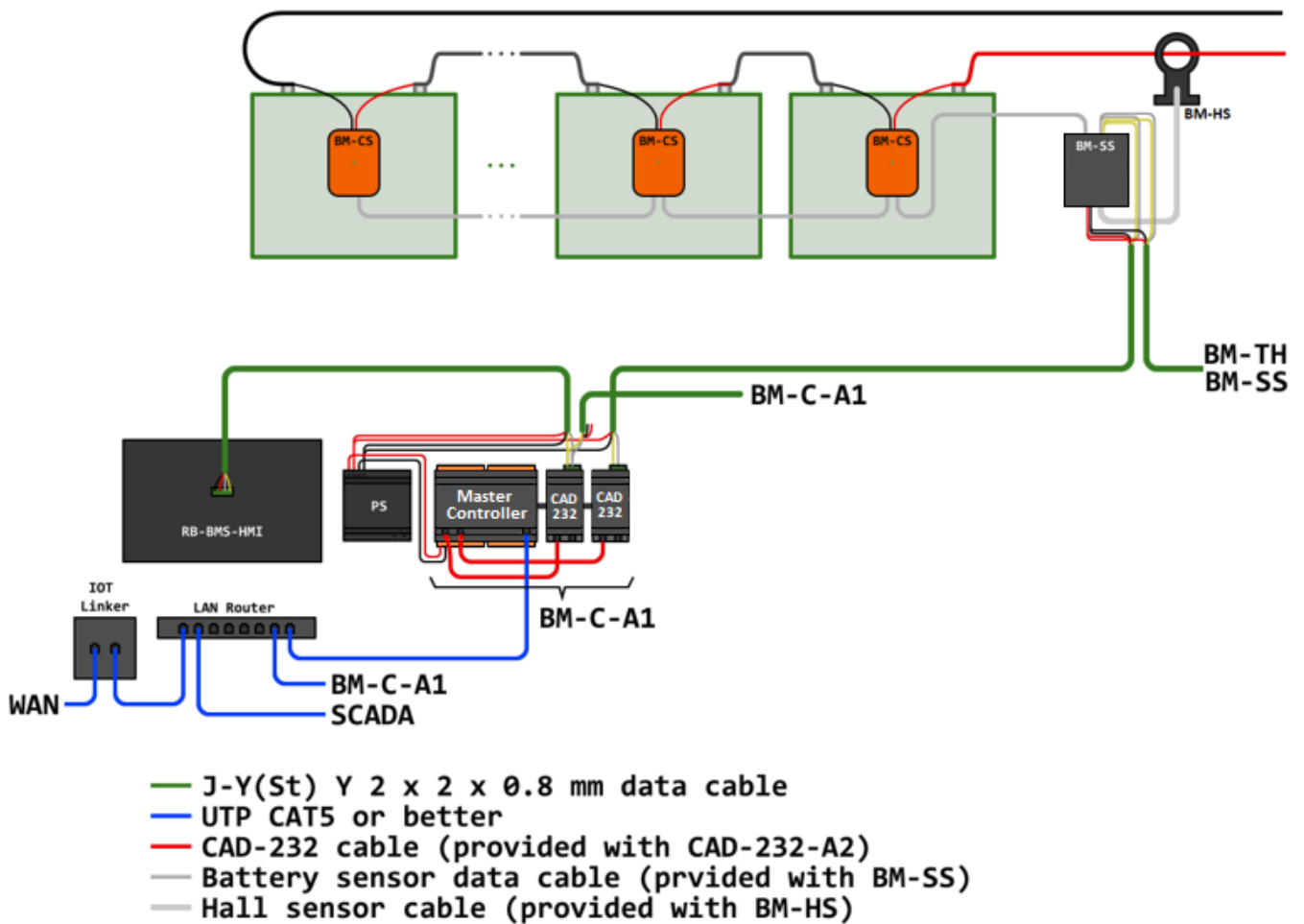

## System components

### BM-C Master Controller



Order code: **BM-C-A1**

### Highlights & Features

- Full control for an UPS system
- Supports up to:
  - 8 strings (8 BM-SS)
  - 960 batteries (8 BM-SS \* 120 BM-SC)
- Standard Modbus/TCP connectivity to SCADA systems

### Technical specification

<b>Power supply</b>	Nominal	24 VDC
	Range	18 .. 28 VDC
<b>Power consumption</b>	Typical	150 mA
	Max	280 mA
<b>Digital outputs</b>	relay 8A/250VAC or 8A/30VDC resistive	
<b>Operating conditions</b>	0..50°C, 0..85% rh non-condensing	
<b>Dimensions</b>	width	185 (110+2×37,5) mm
	height	103 mm
	depth	51 mm

More: [http://wiki.hiq-universe.com/en/hiq\\_hw/mc3-24](http://wiki.hiq-universe.com/en/hiq_hw/mc3-24)

### BM-CS Cell sensor



Order code:	<b>BM-CS-12</b>	for 12 V battery
	<b>BM-CS-02</b>	for 2 V battery

### Highlights & Features

- Real-time cell voltage measurement
- Internal resistance measurement on line
- Negative pole temperature measurement
- Balancing function

### Technical specification

<b>Power supply</b>	BM-CS-02	2 VDC (1.6 .. 2.6 VDC)
	BM-CS-12	12 VDC (7.5 .. 15.6 VDC)
<b>Power loss</b>	BM-CS-02	110 mW
	BM-CS-12	90 mW
<b>Operating temperature</b>	standard	0 .. 45 °C
	max	-10 .. 55 °C
<b>Storage temperature</b>	-40 .. 70°C	
<b>Operating humidity</b>	5 .. 95 % RH, Non condensing	
<b>Dimensions:</b>	width	60 mm
	height	80 mm
	height max	95 mm
	depth	25 mm
<b>Voltage measurements</b>	BM-CS-02	1.6 .. 2.6 VDC
	BM-CS-12	7.5 .. 15.6 VDC
	accuracy	±0.2 %
	resolution	0.001 V

<b>Resistance measurements</b>	range	0.1 .. 50 mΩ
	consistency	±(1.5 % + 25 μΩ)
	repeatability	±(1.0 % + 25 μΩ)
	resolution	0.001 mΩ
<b>Balancing</b>	Current	0.2 A
	Time	1 min

**LED indicator**

<b>Normal operation</b>	Green LED breathing mode
<b>Alarm</b>	Red LED flashing

**Battery SOC is calculated using the default battery characteristic parameters:**

<b>Battery voltage level</b>	<b>2 V</b>	<b>12 V</b>
Float range	-0.02 C* .. +0.02 C*	
Float voltage	2.23 V	13.38 V
Cut-off voltage	1.75 V	10.8 V
Recovery voltage	2.12 V	12.68 V

\* C is the battery capacity

**Wiring & Mounting**

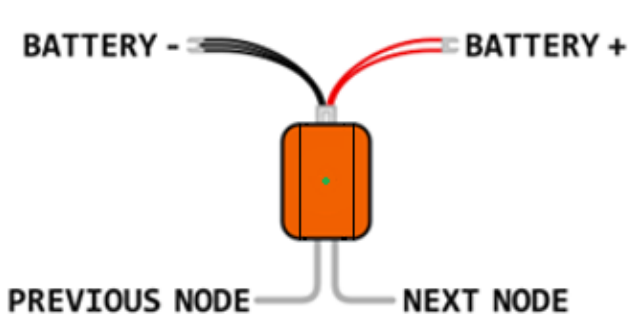

Directly on the battery/cell with the included double-sided sticker



Use the supplied cable with U spade terminals directly for battery/cell wiring

**BM-SS String master**



Order code: **BM-SS-A1**

## Highlights & Features

- Real-time monitoring of string voltage, charge-discharge current, charge-discharge state and string SOC.
- Monitor the voltage, impedance, temperature, SOC and SOH of each battery with BM-CS cell sensors and the specially designed isolated power bus.
- Advanced one-step auto-sensing for individual address. No more manual intervention and setup needed, reducing workload and setup errors.
- Advanced measurement algorithm, no need to discharge large current and measurement can be lossless.
- Balancing function: Keep voltage balanced during the floating charge process of battery pack, keeping the individual battery in the best state, extending backup time and life span of battery pack.
- Communication is based on power-isolated RS485. Secure and stable.
- Quickly locate the alarmed or faulty battery pack in machine room.
- External open Hall Sensor, measuring charge-discharge current in different ranges.
- Isolated voltage in communication interface: AC 3750V
- Supports up to 120 batteries (BM-CS)

## Technical specification

<b>Power supply</b>	Nominal	24 VDC
	Range	12 .. 36 VDC
<b>Power loss</b>	≤ 2W	
<b>Operating temperature</b>	Standard	0 .. 45 °C
	Limit	-10 .. 55 °C
<b>Storage temperature</b>	-40 .. 70 °C	
<b>Working humidity</b>	5 .. 95 %RH, non-condensing	

<b>Dimensions:</b>	Width	85 mm
	Height	105 mm
	Height max	120 mm
	Depth	39 mm
<b>Voltage measurements</b>	Range	20 .. 800 VDC
	Accuracy	± 0.5 %
	Resolution	0.01 VDC
<b>Current measurements</b>	Range	-1000 .. 1000 A
	Accuracy	± 2 %
	Resolution	0.01 ADC

**LED indicator**

<b>Normal operation</b>	Green LED
<b>Alarm</b>	Red LED

**Wiring**

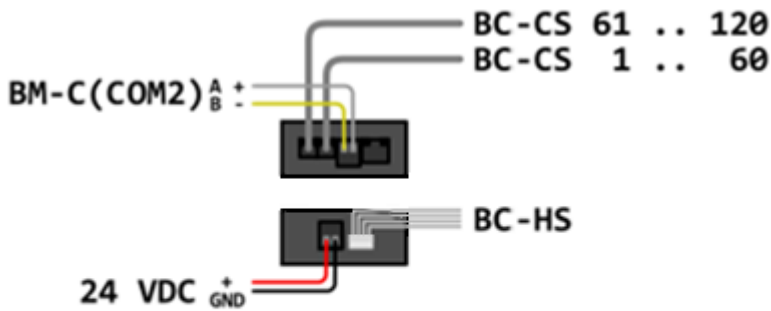

**BM-HS Hall Sensor**





Order code:	<b>BM-HS-50</b>	50 A
	<b>BM-HS-100</b>	100 A
	<b>BM-HS-200</b>	200 A
	<b>BM-HS-300</b>	300 A
	<b>BM-HS-400</b>	400 A
	<b>BM-HS-500</b>	500 A

**Highlights & Features**

- easy installation (split core)

**Technical specification**

<b>Dimensions:</b>	width	95 mm
	height	80 mm
	depth	25 mm
	core inner diameter	40 mm
<b>Current measurements</b>	BM-HS-50	0 .. 50 ADC
	BM-HS-100	0 .. 100 ADC
	BM-HS-200	0 .. 200 ADC
	BM-HS-300	0 .. 300 ADC
	BM-HS-400	0 .. 400 ADC
	BM-HS-500	0 .. 500 ADC
	Resolution	0.01 ADC

**Wiring**

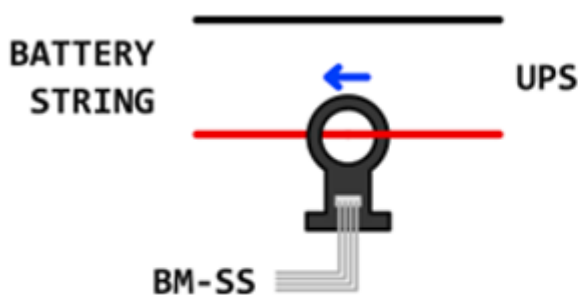

Optional, limited by the length of the included cables  
 For proper mounting, an arrow is marked on the sensor to indicate the direction of the electric current

**BM-HMI touch screen HMI 7"**

[http://wiki.hiq-universe.com/touch\\_hmi\\_panel\\_7inch](http://wiki.hiq-universe.com/touch_hmi_panel_7inch)

**BM-TH Temperature and humidity sensor**

[http://wiki.hiq-universe.com/temperature\\_and\\_humidity\\_sensor](http://wiki.hiq-universe.com/temperature_and_humidity_sensor)

## BM-L IOT Linker

[http://wiki.hiq-universe.com/en/hiq\\_hw/iot\\_linker](http://wiki.hiq-universe.com/en/hiq_hw/iot_linker)

## BM-PS Power Supply

[http://wiki.hiq-universe.com/power\\_supply](http://wiki.hiq-universe.com/power_supply)

From:

<https://wiki.hiq-home.com/> -

Permanent link:

[https://wiki.hiq-home.com/doku.php?id=robotina\\_bms](https://wiki.hiq-home.com/doku.php?id=robotina_bms)

Last update: **2023/03/17 06:11**

