

HIQ home automation

Manual v1.6 rev 4



Content

General

Overview	1
Features	2
Feasibility	3
Layout	4
Usage	5
Expansion	6
Background	7

Features

Lights and blinds	8
RGB dimmer	9
Scene	10
Automatic lights	11
Simple automation	12
Ready light	13
Evo light	14
Heating and cooling	15
Timetable	16
Key concepts	17
Automation	18
Operation	19
Alarm	20
Energy	21
Customization	22

Software

HIQ Configurator	23
HIQ Commander	24
HIQ Universe	25

Hardware

PS-IQ power supply	26
HC-IQ home controller	27
LC-10-IQ light controller	28
LD-V4-IQ LED dimmer	29
LD-P4-IQ universal dimmer	30
LD-D8-IQ DALI dimmer	31
BC-5-IQ blinds controller	32
SC-4-IQ scene controller	33
TH-1-IQ thermostat	34
TH-2-IQ thermostat	35
TH-3-IQ thermostat	36
FC-1-IQ fan-coil actuator	37
SDM-120C power meter	38
IR-580-IQ and other sensors	39
AS-24RA touchless switch	40
Wiring	41
Switch panel	42
Dimensions	43
Order code	44

Overview

sensors - controllers - actuators - interface



- comfort
- simplicity
- security
- safety
- practical
- flexible
- cost-effective

HIQ is a home automation system, including lights, blinds, heating and cooling; temperature monitoring, energy management, timetable, event-based automation and alarm.

HIQ consists of both hardware and software. Devices are connected to each other with a common power supply and communication bus.

Although basically simple, expansion capabilities are virtually unlimited. System is configurable, programmable, and allow integration of multiple HIQ installations into a single functional unit.

HIQ can be used for a new project and renovation. Most of the work is done by a common electrician, no specialized expert is needed. Most of the configuration is done by end-user.

System design is very simple, there are no complicated compatibility or dependency rules.

HIQ is fully open to work with many other home devices, either by integrating them in the system (e.g. touchless buttons), or cooperate on the signal level (e.g. professional alarm).



Features

new concept with unique features

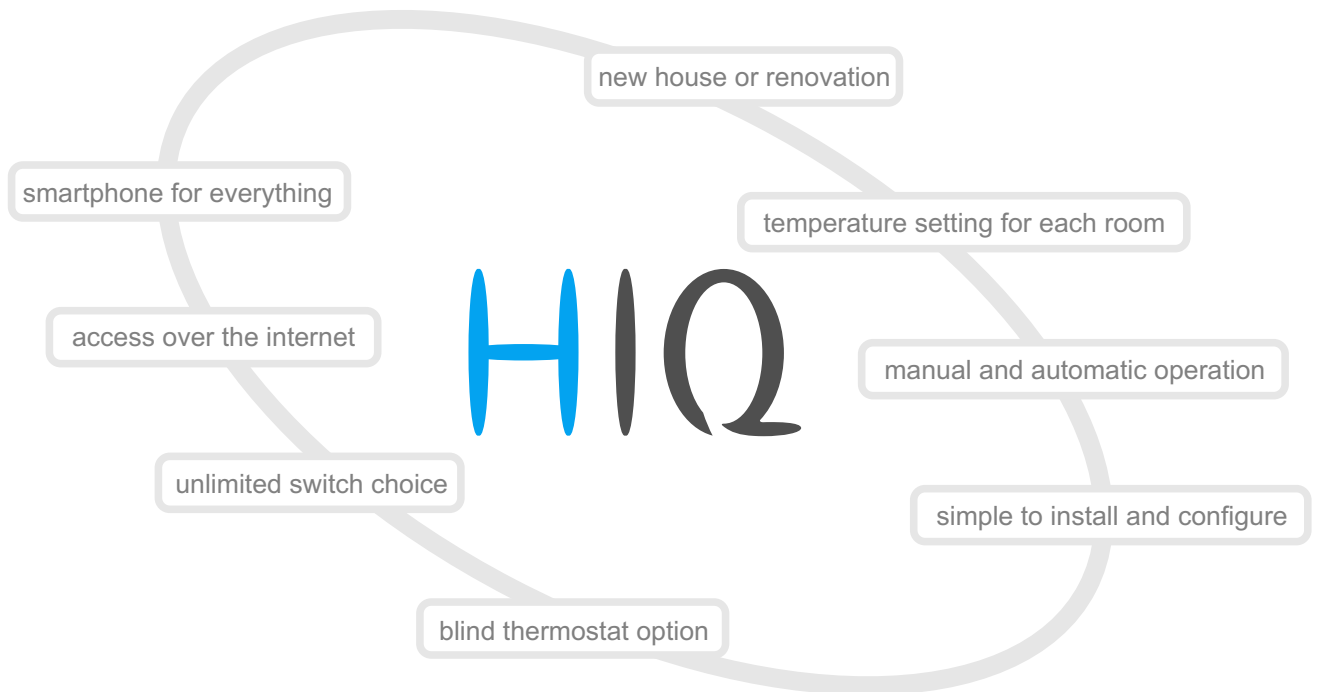
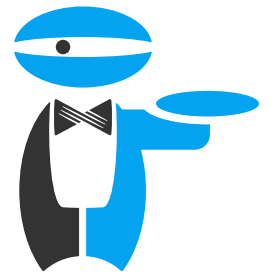

Multiple timetables

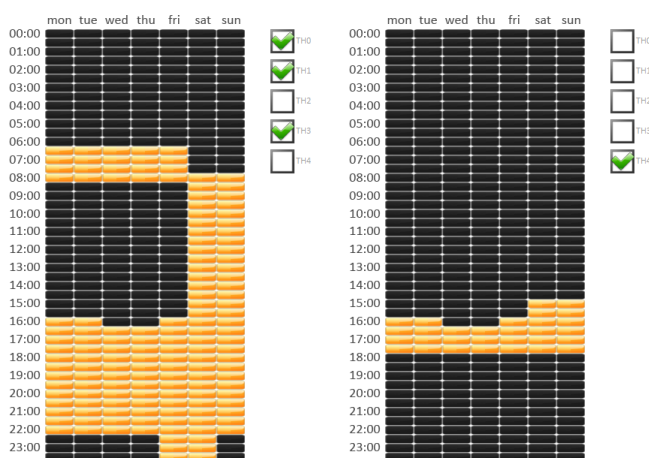

Set things running up to your schedule. To configure the timetable, select active hours, then select devices to be affected. You can manually override output at any time.

Advanced RGB control

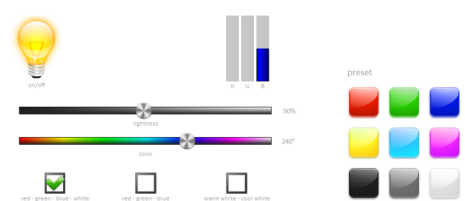

RGB mode allows control of hue, saturation and brightness; instead of individual red, green and blue channels.

In white temperature mode, output goes between different kinds of white, from bright daylight to warm incandescent light.

Evo light function provides synchronization between light temperature and time of day. In the evening, lights will automatically reach the warmer tone.

Feasibility

suitable for most lodging solutions



small house



large house



highrise



apartment building

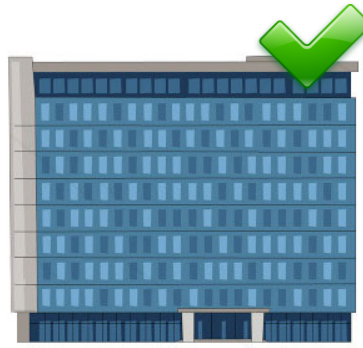

office building



urban house



farm house



cottage



new house



full renovation



partial retrofit

HIQ system is suitable for house or apartment, small or large, residence or weekend house. It may not be the best choice for a partial or temporary retrofit, where wireless solution is preferred.

Layout

from a switch to the cloud computing

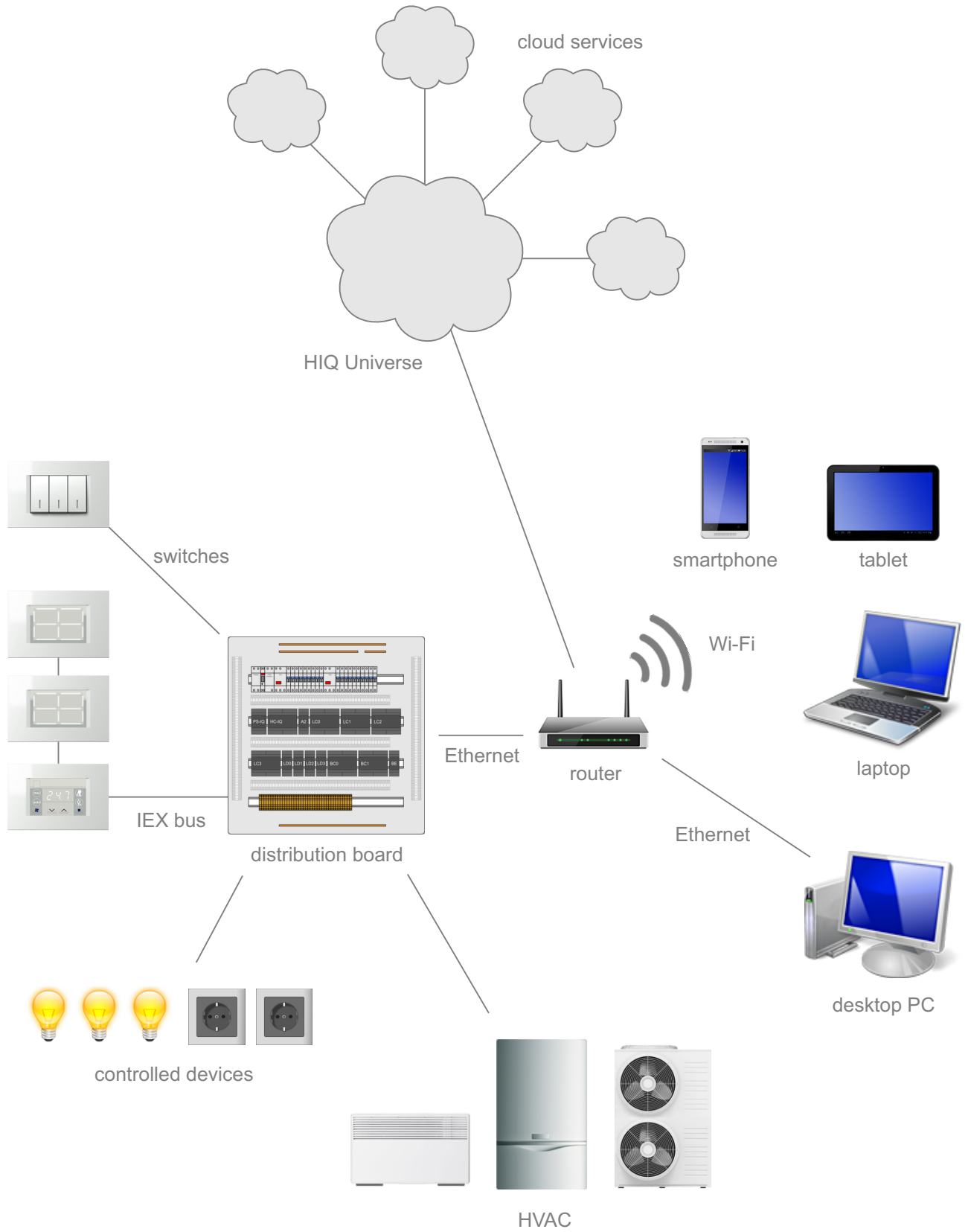

Usage

what all this hardware is for

Device		Used for
	<p>LC-10-IQ light controller</p>	 <p>halogen and LED downlighters, all kinds of general-purpose lights</p>
	<p>LD-V4-IQ LED dimmer</p>	 <p>managed socket for floor lamp, table fan, hi-fi system, projector, and all kinds of appliances</p>
	<p>LD-P4-IQ LD-D8-IQ universal dimmer</p>	 <p>LED stripes</p>
	<p>LD-P4-IQ LD-D8-IQ universal dimmer</p>	 <p>dimnable lights of all kinds</p>
	<p>BC-5-IQ blinds controller</p>	 <p>window blinds, shutters and jalousies</p>
	<p>SC-4T-IQ scene controller</p>	
	<p>SC-4S-IQ scene controller</p>	<p>user-selectable arrangement of lights and blinds</p>
	<p>TH-1-IQ TH-2-IQ TH-3-IQ electronic thermostat</p>	<p>heating, cooling and fan control</p>
	<p>FC-1-IQ fan-coil controller</p>	
	<p>HC-IQ main controller</p>	<p>smartphone and PC connection, automation, timetable, alarm, energy and other functions</p>

Expansion

out-of-the-box and project-based features

Basic system

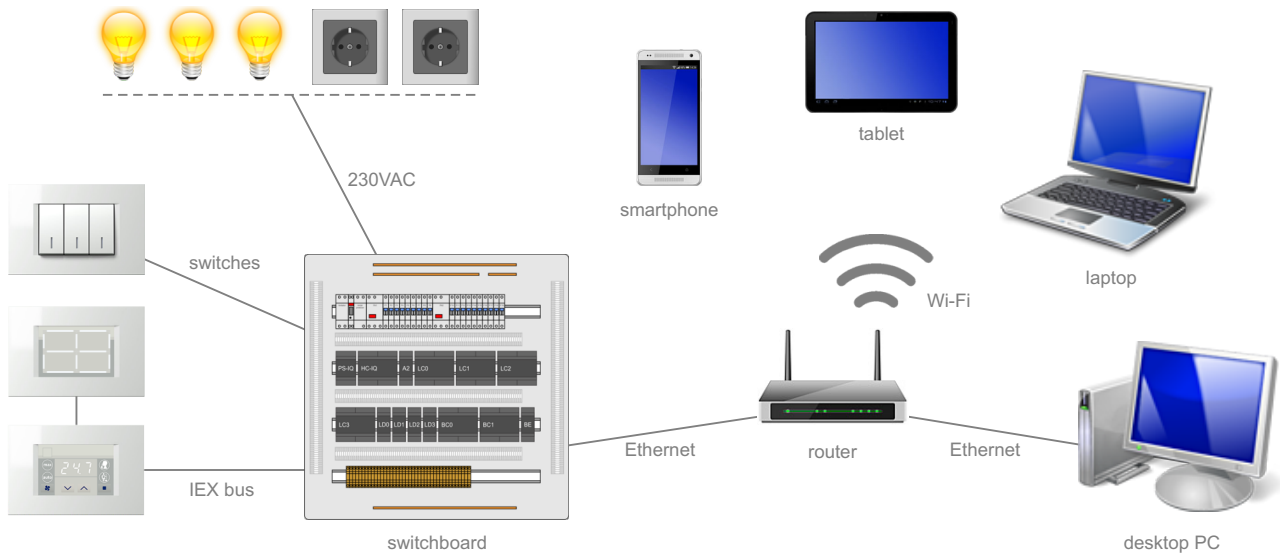

Basic system covers approximately 200m², or one floor of a multistory object.

Advanced system

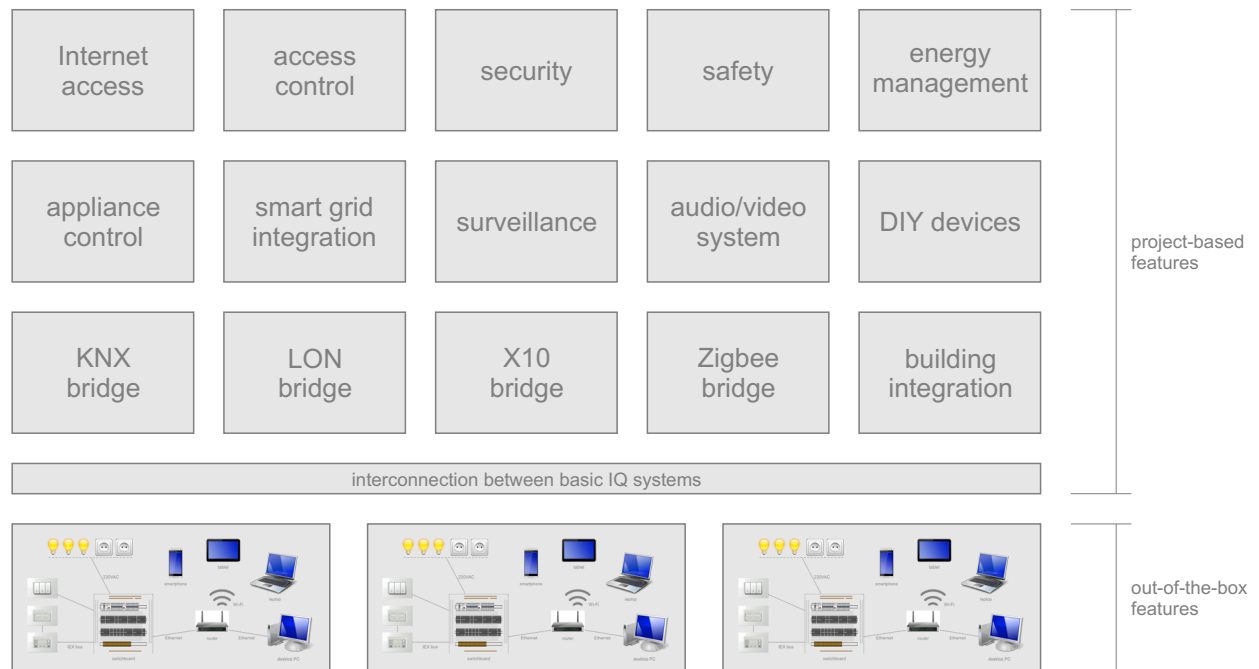

HIQ system offer many out-of-the-box functions. However, modern home automation is all about integration, and that is where the HIQ excels. HIQ is capable of connecting various devices into a functional system. Integration is project-based, each home is attuned to investor and building requirements.

Background

technical experience behind the product

Design

Cybrotech originate from industry control and automation, all devices are designed and build up to a much higher standards then usually expected in home automation.

Features

- hardware watch-dog
- transient supression
- short circuit tolerant outputs
- reverse polarity tolerant supply
- wide temperature range

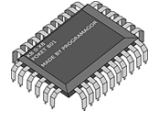

Addressing

Devices are addressed automatically, not a single address is set by user.

Firmware

All devices are build to implement firmware upgrade, so the future for your investment is assured.

Responsive

From keypress to action, typical reaction time cca. 10 milliseconds.



CAN bus is a multi-master, deterministic bus which offer optimum between performance, network architecture and cost.

Power consumption

HIQ take a great care to use as little electricity as possible.

Autorange inputs always ensure a full scale motion.



No batteries

The whole system is operated from a single 24V power supply.



No hidden costs at any level - everything is simple and elegant (and beautiful, too).

Programming tools are free, everybody is welcome to give it a try. Only a basic programming skills are needed. Join our group and discover how fun and simple house automation can be.



Wire vs. wireless

- no batteries
- more reliable
- faster response
- less EMI pollution
- simpler setup
- lower price



We don't sell switches, luminaries, computers, portable devices, tablets or phones; you have a freedom to select anything you like, buget models or expensive designer items. What we do sell is electronics, software and home automation experience at it's finest.

Lights and blinds



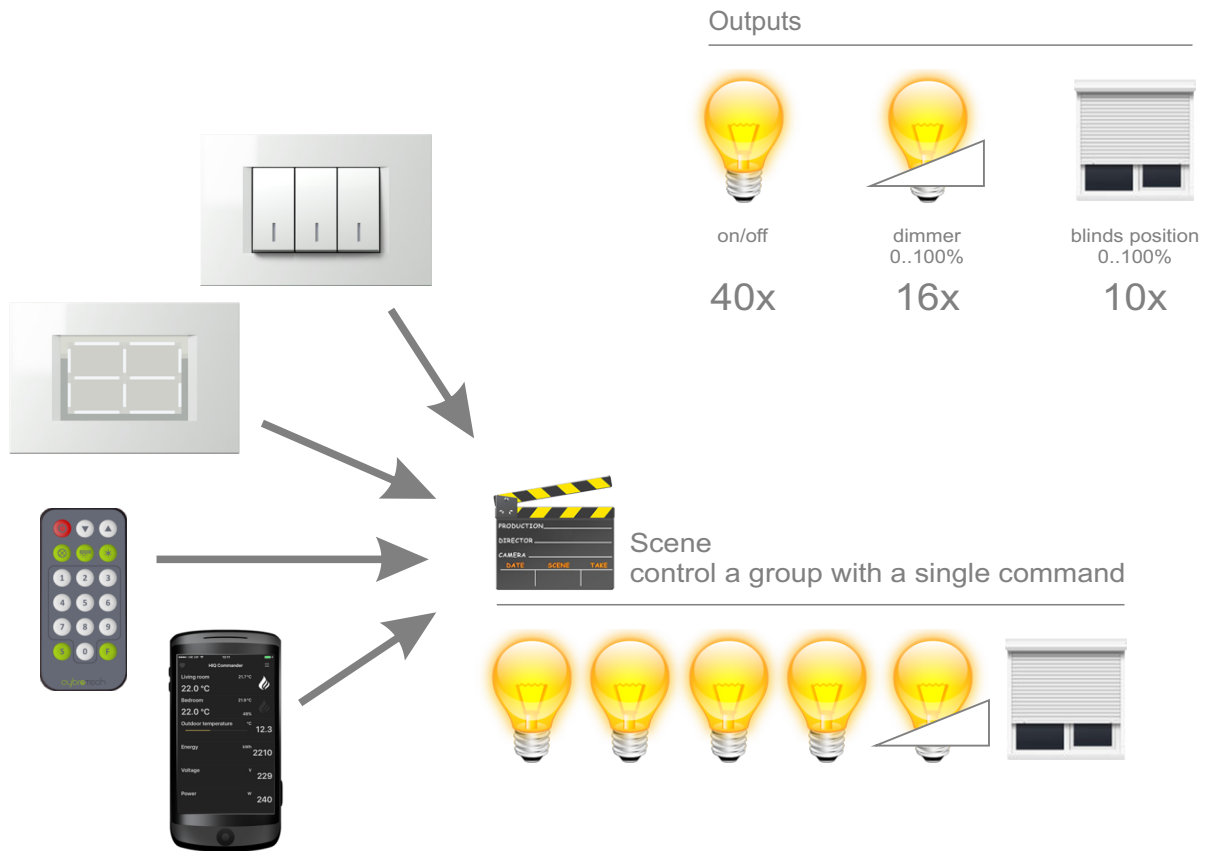

control everything from everywhere



Light type

-  incandescent/halogen
-  compact fluorescent
-  compact LED E27/E14
-  LED strip 12/24V

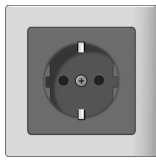
Blinds type

-  classic blinds
-  slatted blinds
-  Roman shades
-  managed socket for a floor lamp, table fan, dehumidifier, electric mosquito repellent, hi-fi system
-  blinds control with an intermediate position

RGB dimmer

hue, saturation and brightness

In RGB mode, dimmer channels are connected to red, green, blue and white lights. White channel is optional. Instead of individual channels, user controls total brightness, hue and saturation.

RGB dimmer may be used in white temperature mode. Here, user controls brightness and white temperature. White light is obtained by mixing all four channels. For the best results, RGB strip 5600K and white strip 2700K (warm white) must be used.

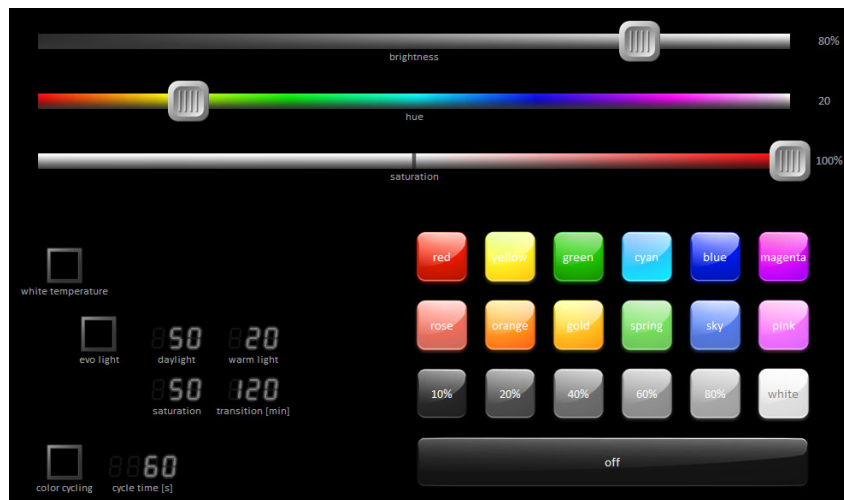

White temperature

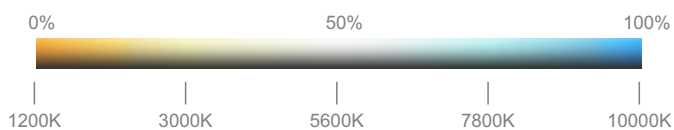

In RGB mode, saturation goes from natural white (white strip) to RGB white (0..50%), and then to selected color (50..100%).

In white temperature mode, saturation goes from natural white (white strip) to RGB white (0..100%).

Color cycling

Automatically rotate through the available colors. Brightness and saturation are selected manually.



Color picker

Color picker is a quick way to choose a color, available with the HIQ Commander application. To control the RGB, just touch a color or slide finger over the screen.

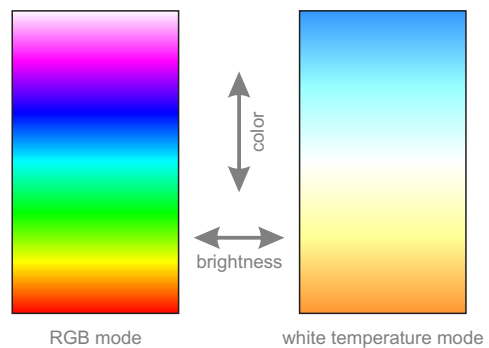

Scene

one touch to rule them all



Scene is user-defined memory including lights, dimmers and blinds. Each output is either defined by scene (on/off, lightness and position), or not affected.

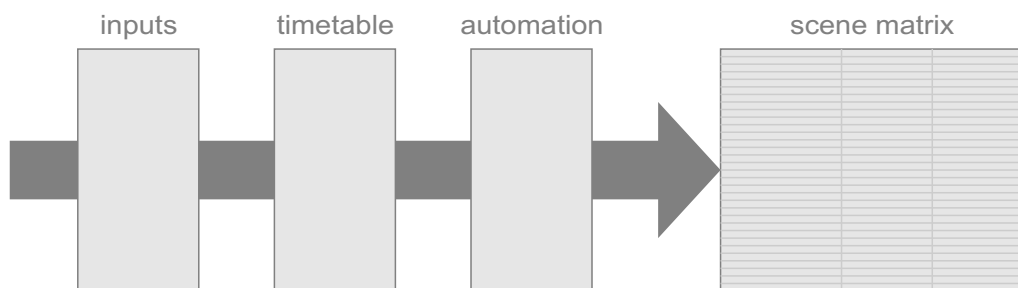

Scene mapping

SC0	0
	1
	2
	3
SC1	4
	5
	6
	7
SC2	8
	9
	10
	11
SC3	12
	13
	14
	15
	16
	17
	18
	19
	20
	21
	22
	23
	24
	25
	26
	27
	28
	29
	30
	31

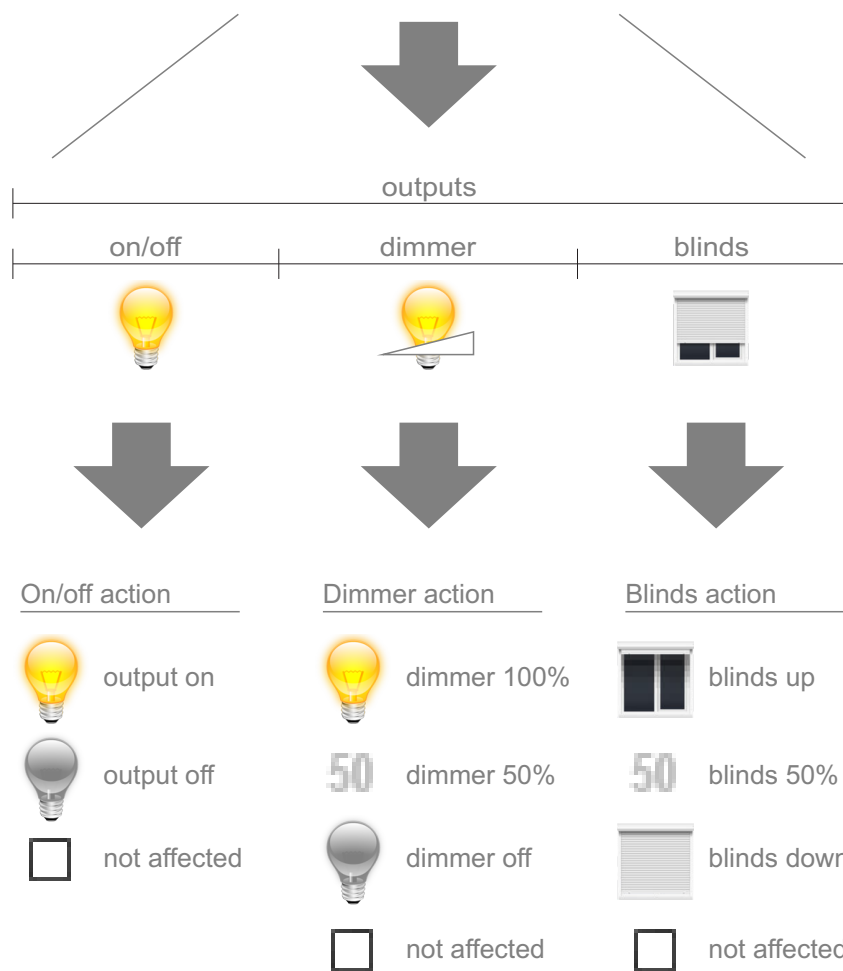

Hint: use scene 31 to turn all lights off.





Scene is initially created with HIQ Configurator. Once saved, it can be modified with a long press.

Automatic lights

where and how to use automatic lights

Benefits of automation depend mostly on how the space is used:



-  smart light
-  ready light
-  motion sensor
-  door sensor
-  manual control

Smart light is based on low light and presence signal, and it is used for a main living space. It can be combined with evo light to control light temperature during the evening.

Ready light take advantage of door and motion sensors. It is suitable for a space used occasionally, like a bathroom.



Motion sensor cover open spaces, hallway or porch.

Door sensor cover small rooms used temporary, like a closet, cloak or wardrobe.

Other areas, like a bedroom, are handled manually.

Simple automation

light automation based on a single sensor

usage	input mode	output mode	description
on/off			press on, press off
on/off + timer			press on, press off in case light is left on, timer turns it off
staircase			press on press again to reload the timer when timer expires, light goes off
doorbell			press on, release off
scene			press to set scene press again to turn the scene off
motion sensor			movement is keeping the light on when timer expires, light goes off
			movement is keeping the light on when timer expires, light goes off active only during the night
door sensor			open door to turn the light on close door to turn the light off
			open door to turn the light on close door to turn the light off active only during the night
ready light	 		used for ready light only

Ready light

advanced automatic light control

Ready light is an advanced lighting system, based on motion and door sensors. It is best suited for closed spaces that residents don't occupy permanently.

Features:

- instant turn on when door begins to open
- never turn off while people are inside
- quickly turn off when people get out

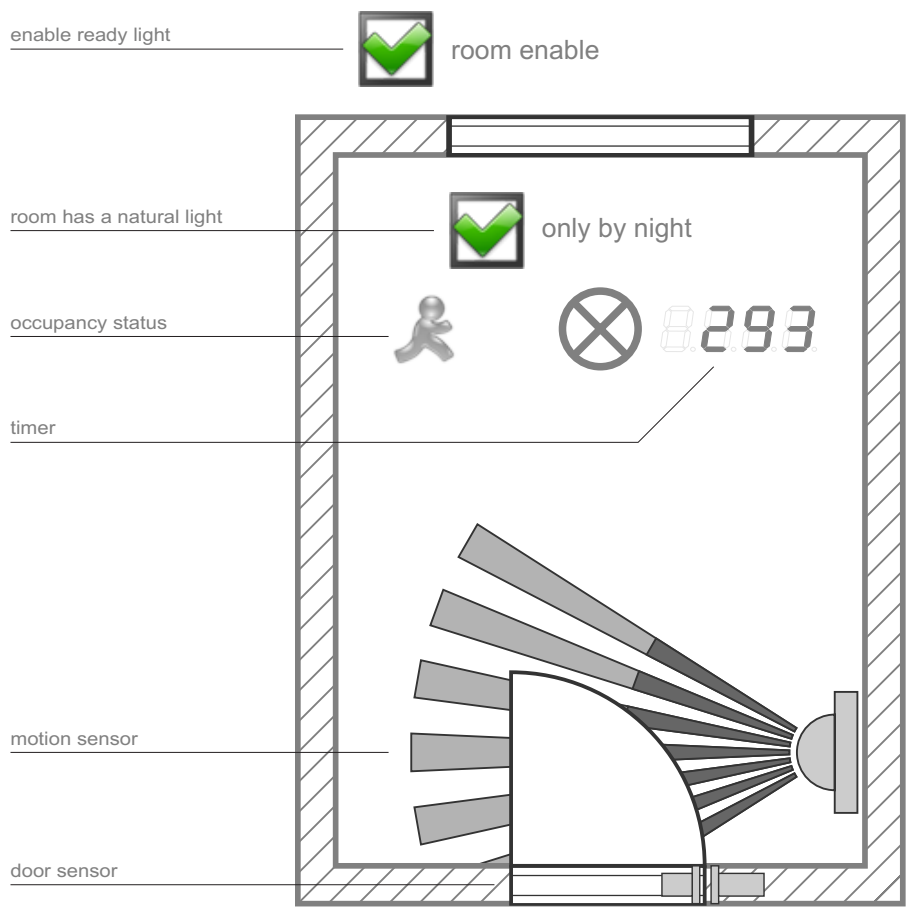

Input setup

Sensors are connected to spare inputs of light controller. Input must be configured to ready light mode.

Sensor placement

For a best result, sensor must be activated just after person closes the door.

Short timeout

Time from closing the door to light off. If time is too short, light may turn off after entering the room.

Long timeout

Time from leaving the room to light off, without closing the door.

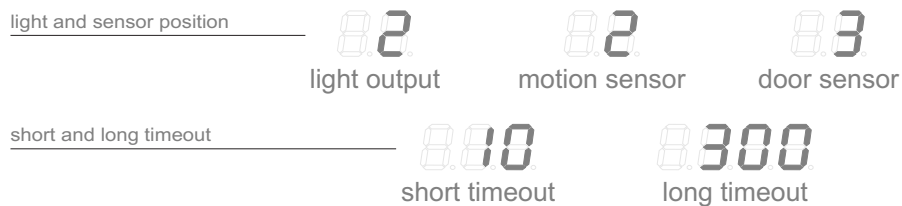

Patent pending - Ready Light is in the proces of acquiring patent rights.

How it works

When door begins to open, reed sensor is activated and the light turns on. When a person enters the room and closes the door, PIR activation means person is surely in the room. As long as door is closed, light will stay on. When person leaves room and closes door, system will wait for a short time, then turn the light off. If the door is left open, long timeout is active. If the PIR sensor is not activated during that time, light switches off.

Evo light

warm light at late evening

Evo light is a half automatic system for controlling temperature of white light. It operates with RGB dimmer in white temperature mode. User controls brightness, hue and saturation are controlled by the system.

When enabled, it first produce a cool white light, then a warm light later in the evening, not disrupting the natural sleep cycle.

System can be combined with smart lights. In that case, operation is fully automatic, smart light controls brightness, and evo light controls light temperature.

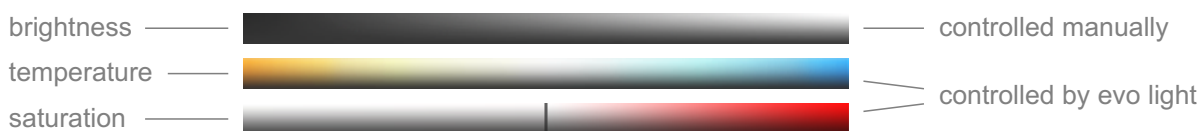

Term evo is a short for 'evolution'. During the most of our evolutionary past, our ancestors were using no artificial lighting, so daily rhythm was synchronized only by sunlight. Evo light is an attempt to mimic that natural conditions.

Operation

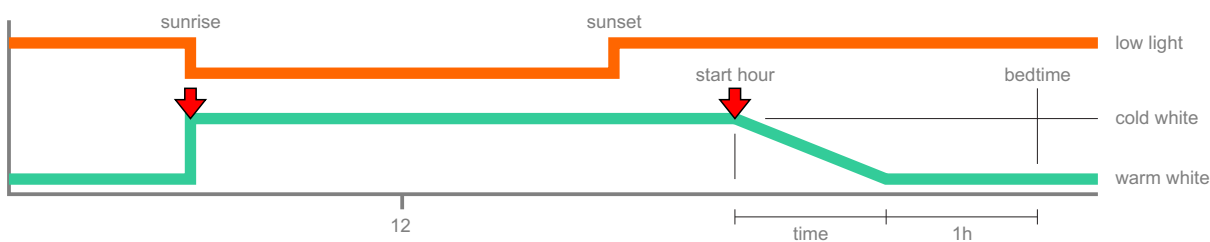

To configure evo light, first experimentally find the best light for early and late evening. Start hour and transition time should be configured so the warm light is reached at least one hour before bedtime.

When dimmer is switched back to RGB mode, evo light will automatically stop. Enabling again, it will catch on correctly, recalculating the new parameters.

Note: evo light setup is on RGB dimmer page. It can't be reached if RGB dimmer is not connected to system.

Heating and cooling

general features of heating/cooling system

Heating/cooling

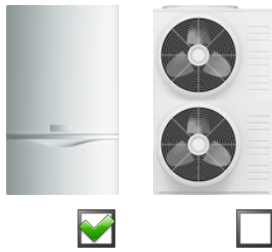

Energy demand

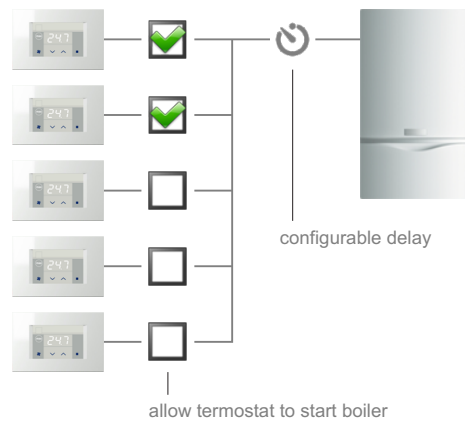

Up to five regulation zones are supported, each with their own thermostat. Generally, energy comes from boiler for heating and chiller for cooling, but other combinations are possible.

Thermostat



Actuator

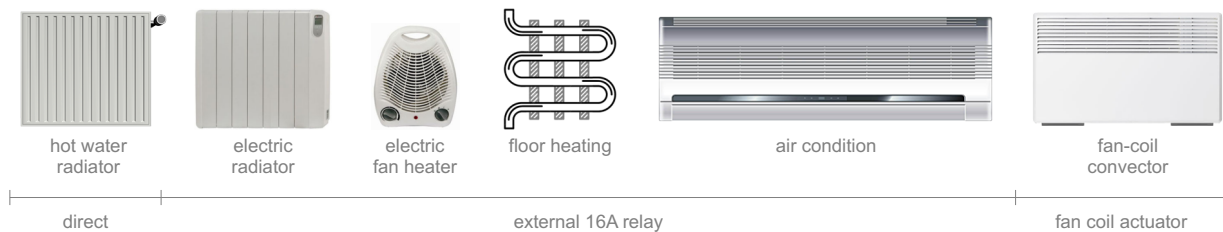

System is versatile enough to handle most actuator options. Hot water valve is connected directly, others require either external power relay, or fan coil actuator. Different actuator types can be mixed.

Examples

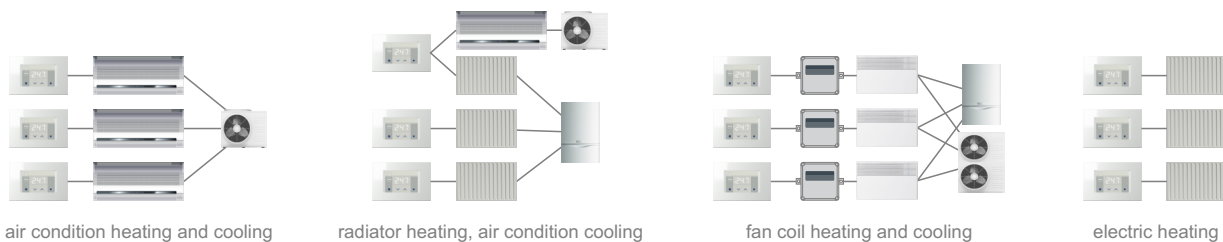

Timetable

weekly event scheduler

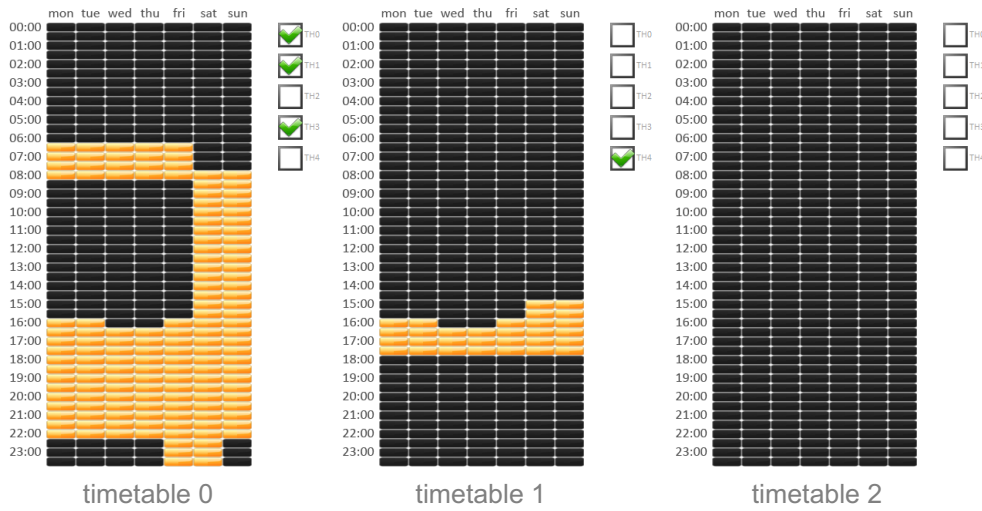

The last timetable can directly control an output or apply a selected scene.

Selected part is a period when heating system is active. Each rectangle represents a half hour. Tables are fully independent of each other. To set multiple fields, hold left button and drag mouse.

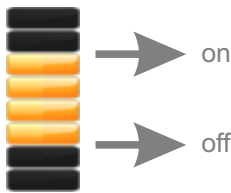

Each continuous block create on and off event.

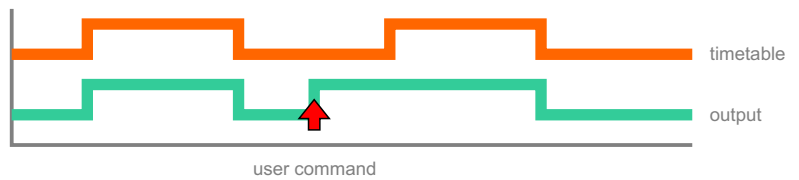

When timetable controls an output, manual override is possible at any time, timetable will catch on with the next transition.

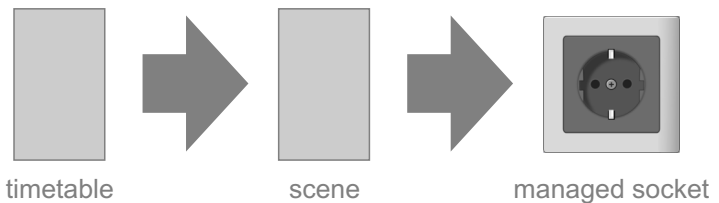

Timetable can be used to control mostly anything. Use a managed socket to create a time plan for your devices.

Key concepts

low light and presence indicators

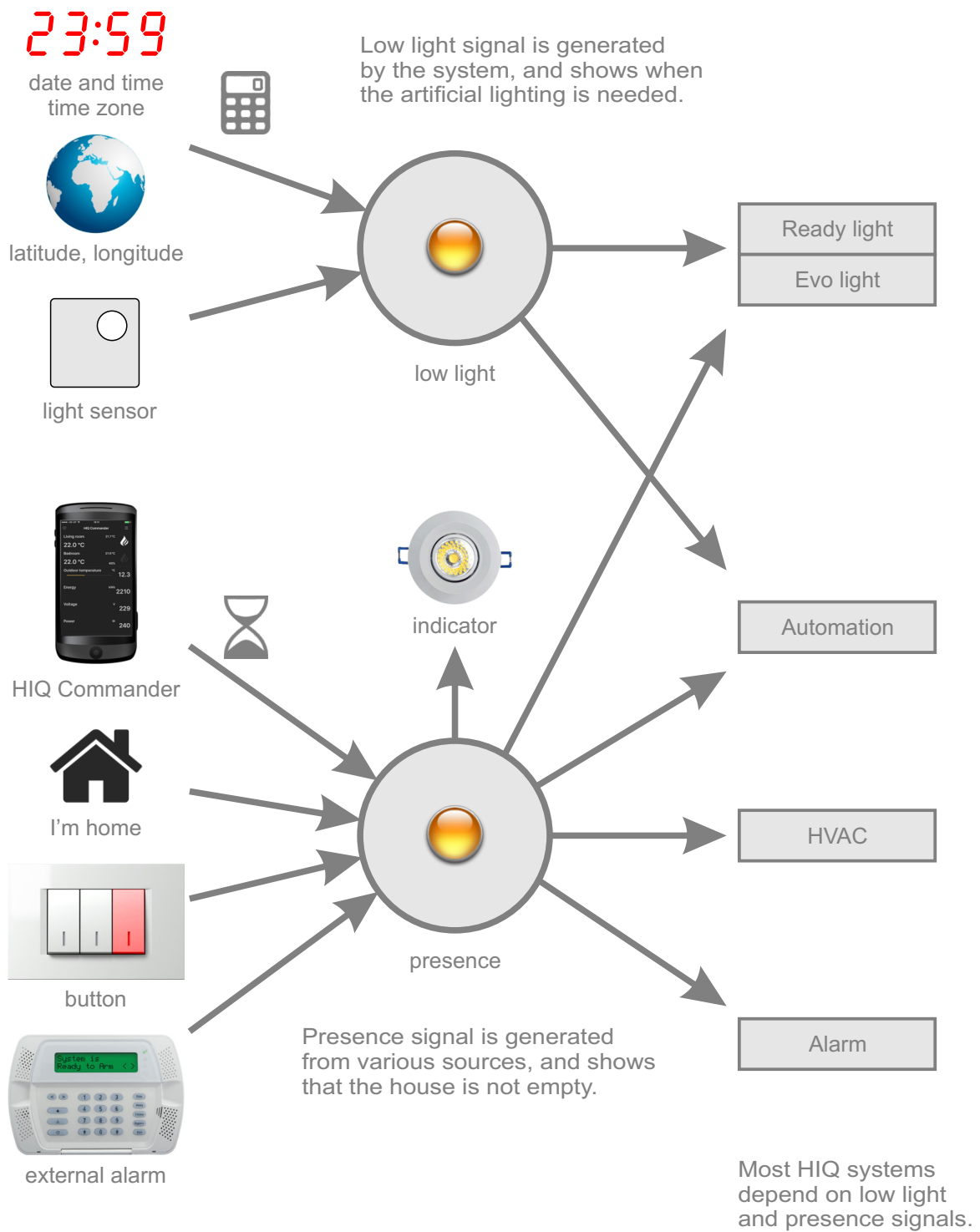

Low light goes up and down once a day.



Presence goes up and down as you going out and coming home.

Automation

execute tasks automatically



Coming home

Let your house show how happy it is when you come back home. When phone connects to your wi-fi network, lights and heating will turn on automatically.



Default setpoint

When active, setpoint adjustment is valid for about half hour, then it returns to the predefined, optimal temperature.



Leaving home

When you leave the house, smartphone disconnects from home wi-fi network, a few minutes later system will turn lights and heating off.



Bio offset

Following your natural biological rhythm (chronotype), let the house be just a little warmer at the specified time of the day, morning, evening or both.



Comfort wake up

System will turn thermostat on a predefined number of minutes before smartphone rings, whenever you set the alarm.



Connect charger

Charge your smartphone every night? Use this action to automatically turn heating and lights off.



Sunny wake up

Wake up naturally, by gradually lifting blinds and let the sunlight wake you up, a predefined number of minutes before smartphone alarm.



Disconnect charger

Smartphone is charged until morning, right? When disconnecting the charger, automatically turn heating and lights back on.



Smart lights

In the evening hours, when sunlight goes down, automatically set evening scene, turn on the lights and lower blinds. Works only when tenants are at home.



Call notification

When you receive a call, selected light will turn on and off a couple of times, to bring the attention when phone is away or silenced.



Random lights

When nobody is at home, discourage snooping with a simple deception: turn lights on and off to leave impression that house is not empty.



Text notification

When you receive a text message, selected light will turn on and off a couple of times, to bring the attention when phone is away or silenced.

The most frequent question about home automation is - how to turn the damn thing off. However, regardless the inglorious reputation of smart machines, we strongly believe HIQ will gradually grow up into your daily routine. Events are generated automatically, you are in charge to assign actions according to your preferences.

Operation

automation tasks explained

Comming and leaving



Use presence signal to trigger heating, and set a desired scene.

Bio offset

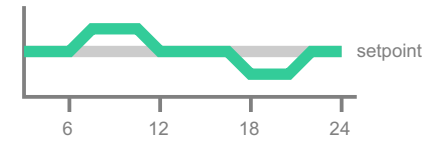

A minute temperature correction depending on time of the day. Adjustable to warmer or colder.

Warm wake up

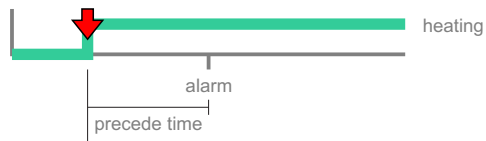

warm wake up

Turn the heating on a few minutes before the alarm clock.

Sunny wake up

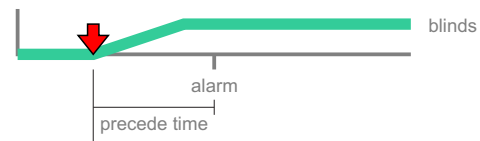

sunny wake up

Lift the blinds up a few minutes before the alarm clock.

Smart lights

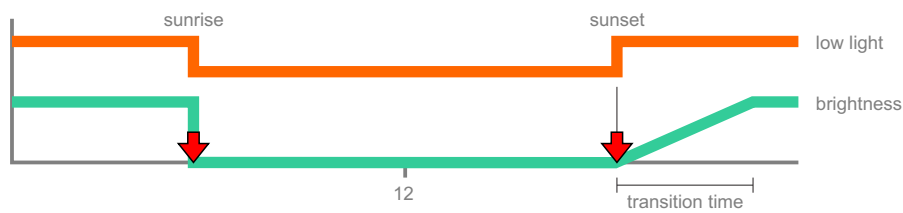

Automatic lights with an optional slope control, synchronized with the sunset.

Smart lights are aware of, but not triggered with presence signal. To activate lights on returning home, use comming home event.

Random lights

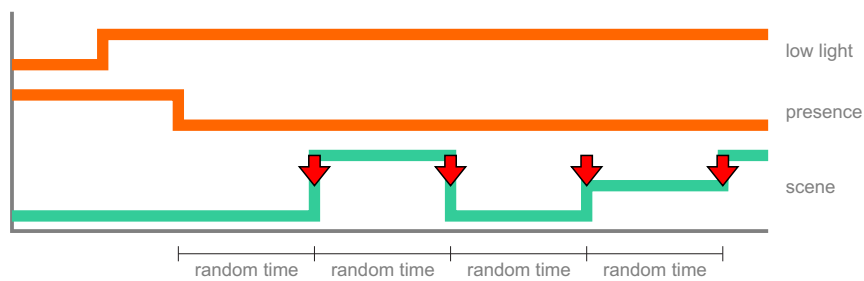

Turn the lights on and off to leave the impression that house is not empty, to discourage burglars.

Alarm

security at no additional cost

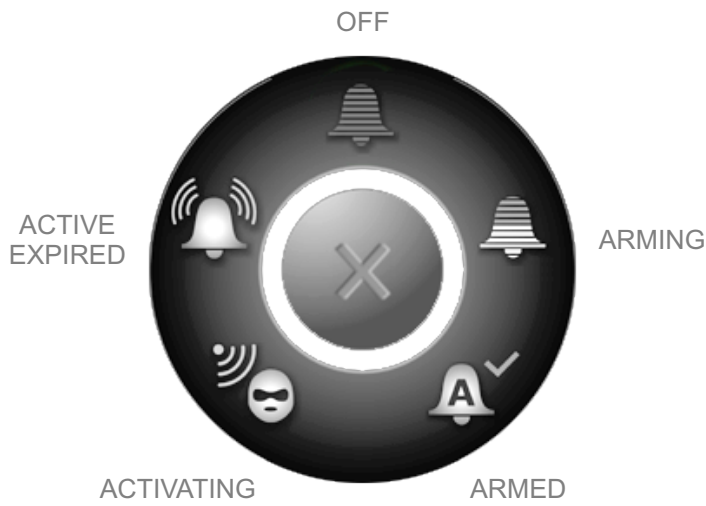

OFF	alarm inactive
ARMING	alarm turned on and will be armed when time expires (default 30s)
ARMED	alarm ready, no intrusion
ACTIVATING	sensor activated, alarm has to be turned off before delay time expires (default 30s)
ACTIVE	burglary, siren output active
EXPIRED	delay time expired, siren is turned off (default 120s)

Alarm on/off

- longpress on a selected wall switch
- smartphone using HIQ Commander
- smartphone by connecting to wi-fi (Android only)
- PC with HIQ Configurator
- PC with HIQ Configurator and 4-digit code
- automatically with presence signal

On/off indicator

- small light connected to an output
- blinking of a selected light
- smartphone with HIQ Commander
- PC with HIQ Configurator

Recommended zone covering

- zone 0 - house exterior
- zone 1 - ground floor, living area
- zone 2 - first floor, sleeping area

Zone settings

- residents at home: 0 (minimum security)
- residents sleeping: 0 + 1 (partial security)
- residents away: 0 + 1 + 2 (full security)



zone 0



zone 0+1



zone 0+1+2

Energy

electricity measurement

Energy monitoring is the first step to efficient energy usage. Once knowing how much energy something is using, one can make a rational strategy for saving.

Required hardware

SDM-120C power meter
CAD-232-A2 converter

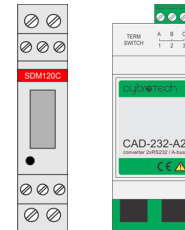

Energy consumption in last 30 days [kWh]

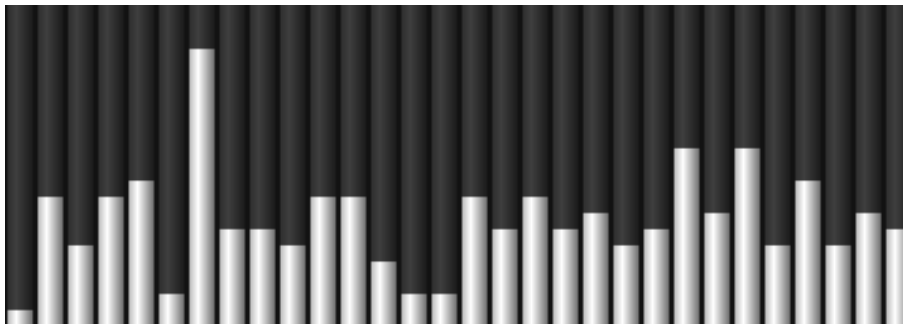

Bargraph for last 30 days is a quick way to check for an excess consumption.

Energy by output

Power count - a number how many times the output is turned on.

Working hours - total number of hours the output spent in on state.

Nominal power - output power configured by user. It can be measured by resettable power meter, or read from the label.

Current power - output power at the current moment.

Energy today - total energy used from last midnight, expressed in Watt-hours.

Energy total - total energy consumed by the specific output.

How to measure the amount of electricity something is using

1. Turn the output off.
2. Reset relative power.
3. Turn the output on.

A few seconds later, measured relative power is displayed. If the reading is not stable, temporary turn off any load which may consume variable amount of power.

Measured rating may be used to set the nominal power on 'By output' page.

Customization

get the maximum out of your system

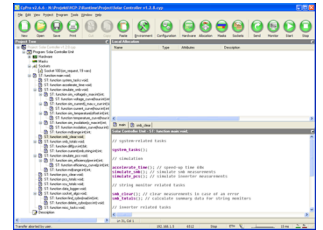

integrated development environment

The main goal of customization is to upgrade functionality up to some specific requirements. HIQ system is flexible and open for modifications of any kind. This page will give a short overview of kind of modifications possible.

Customization is for the one who wants to get the maximum out of the system. It requires a basic programming skills. Programming language is «structured text», a kind of very simplified Pascal. Development environment (editor, compiler, on-line monitor) is called CyPro, and it is free to download from www.cybrotech.co.uk.

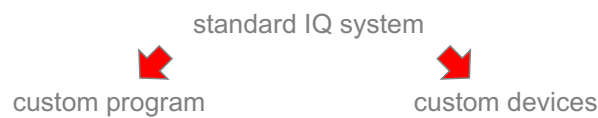

Modify HIQ program

- get main program source directly from controller
- put your code into custom_algo module
- send modified program back to controller

Combine HIQ and non-HIQ modules

- all HIQ modules are fully IEX compatible
- delete unused HIQ modules for hardware setup
- add your own selection of IEX modules
- modify program according to your needs

HIQ Commander for non-HIQ applications

- allocate variables for autodetection manually
- use allocated variables in your cybro application
- for more details, check Cypro example

Non-standard HIQ configuration

- custom selection of modules, e.g. 10x LC-10-IQ
- hardware setup, manually add new modules
- adjust program and mini scada up to your needs

Modify mini scada up to your needs

- no special environment is needed
- configuration consist of one text file and images
- use any image editor to create custom graphics
- create a custom application for Android or iPhone

Connect HIQ systems together

- create system as big as you like
- use sockets as a link between controllers
- implement global commands like «turn all lights off»

Example

Task: count how many times a light is switched on

1. CyPro

- allocate variable lc00_qx00_count, make it retentive
- add the following lines of code into program
- send program to controller

2. Mini scada

- open CyBroMiniScada.xml in text editor (Notepad)
- add object to xml configuration, inside the first page
- use scada (ctrl-E) to move object to the right place



```
if fp(lc00_qx00) then
  lc00_qx00_count:=lc00_qx00_count+1;
end_if;
```

```
<object>
  <type>led</type>
  <var>c1000.lc00_qx00_counter</var>
  <digits>4</digits>
  <decimals>0</decimals>
  <zeroblanking>1</zeroblanking>
  <sign>0</sign>
  <ledcolor>FF0000</ledcolor>
  <height>42</height>
  <x>100</x>
  <y>100</y>
</object>
```

HIQ Configurator

PC application for system setup and configuration



Install

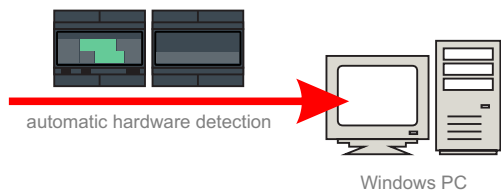

Edit name:
ctrl-E - edit mode
right click - rename
ctrl-E - return to normal mode

HIQ Configurator

- control center for everything
- universal configuration tool
- screen resolution 1366x768

HIQ Timeplot

- timeplot for temperatures
- timeplot for consumed energy
- screen resolution 1920x1080

HIQ View

- template for custom app
- replace floorplan image
- add and rearrange icons

HIQ Simulator

- test all without the hardware

Configuration

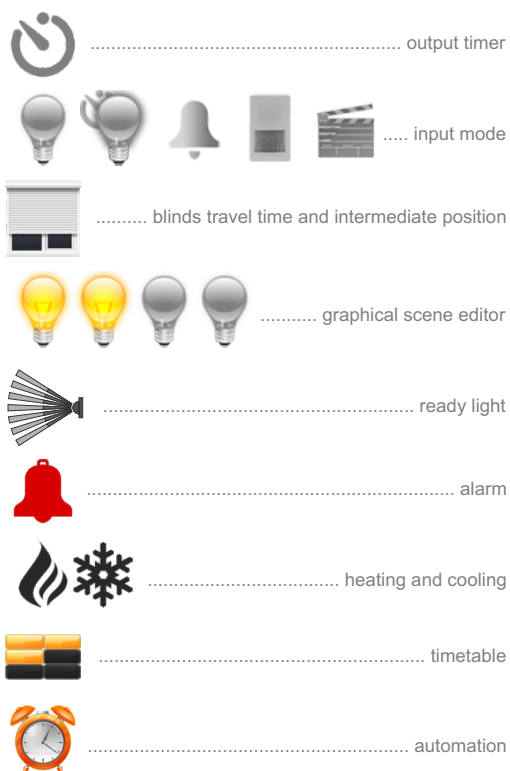

System limits

4x		LC-10-IQ light controller	40 on/off outputs
4x		LD-V4-IQ LED dimmer	16 dimmer channels
or		LD-P4-IQ universal dimmer	
4x		LD-D8-IQ DALI dimmer	
2x		BC-5-IQ blinds controller	10 blinds
4x		SC-4-IQ scene controller	16 scenes
5x		TH-1-IQ thermostat	5 regulation zones
5x		FC-1-IQ fan-coil controller	
1x		HC-IQ main controller	one central controller

Autodetect

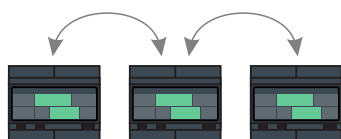

To switch from controller to controller, use Autodetect function.

Autoaddress

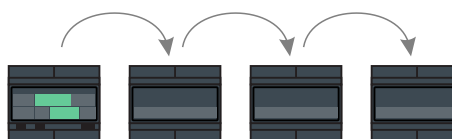

To get all modules in order, use Autoaddress function.

HIQ Commander

application for your smartphone

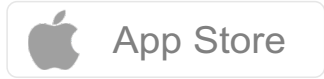

Autodetect

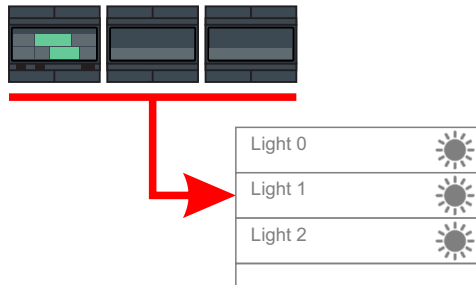

Multiple HC controllers are listed one after another. Number of controllers is limited only by practical matters.

Rename



Rearrange

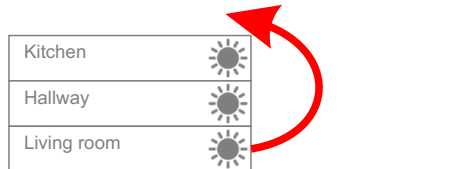

Remove

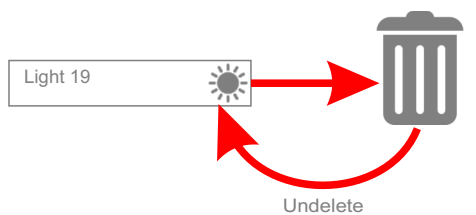

Change icon

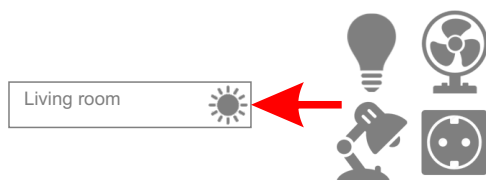

Features



Features	Android	Apple
direct control for all objects	+	+
coming home leaving home	+	×
warm wake up sunny wake up	+	×
smart lights random lights	+	+
default setpoint bio offset	+	+
connect charger disconnect charger	+	×
call notification text notification	+	×
export configuration to another phone	×	+

Limits

HIQ Commander will autodetect more devices than nominal system limits:

- 10x LC
- 10x LD
- 10x BC
- 10x TH

Additional devices are used for project-based features.

HIQ Universe

cloud service for internet access



HIQ Universe

Your home, smarter



Email
 Password
 Keep me logged in

[Forgot password](#)

Robotina
copyright (c) 1998-2016, all rights reserved

HIQ Universe

Create new account

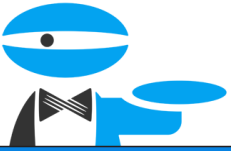

Email
 Password
 Repeat password

 Keep me logged in

[Contact](#)
[Privacy](#)
[Terms](#)

HIQ Universe

damir.skranec@cybrotech.hr

Status **Controllers** Phones Settings Logout

Controller status

● 14767
● 15234
● 15778 communication error

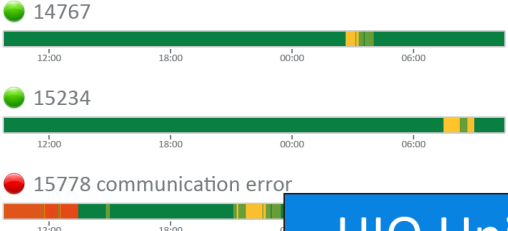

Robotina
copyright (c) 1998-2016, all rights reserved

HIQ Universe

damir.skranec@cybrotech.hr

Status **Controllers** Phones Settings Logout

Serial	Description	Created	Last push	Status	Properties	Ping	Enable	Delete
14767	basement	2015-10-20 08:00	2015-11-20 11:20	●		✓	✓	-
15234	1st floor	2015-10-20 08:00	2015-11-20 11:20	●		✓	✓	-
15778	2nd floor	2015-10-20 08:00	2015-11-20 11:20	●		✓	✓	-

Robotina
copyright (c) 1998-2016, all rights reserved

[Contact](#)
[Privacy](#)
[Terms](#)

PS-IQ power supply

power source for the whole system

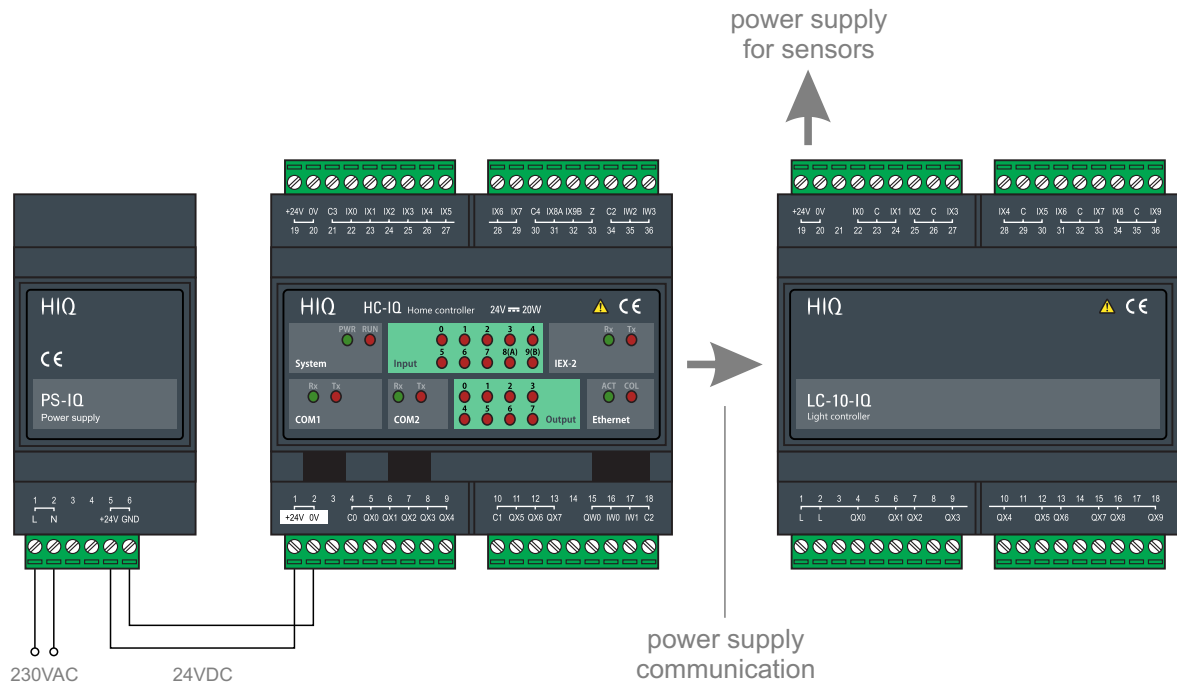

Backup power

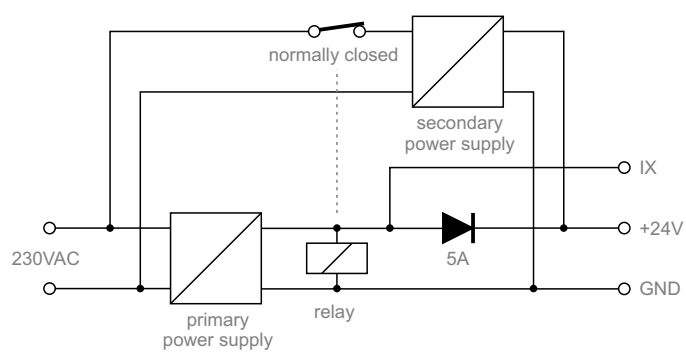

Power supply is usually the most vulnerable part of the system. To prolong service life, secondary power supply may be added. When primary source is broken, the secondary takes on, so the operation is not interrupted. As secondary supply is connected to power only when first breaks, the same service life can be expected as the primary one. A spare input can be used as failure signal.

HC-IQ home controller

home automation main controller



Mounting: 35mm DIN rail 6M

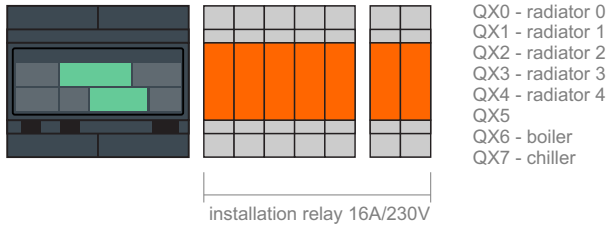
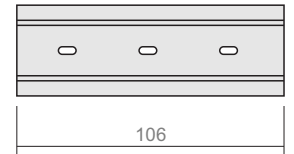

- QX0 - radiator 0
- QX1 - radiator 1
- QX2 - radiator 2
- QX3 - radiator 3
- QX4 - radiator 4
- QX5
- QX6 - boiler
- QX7 - chiller

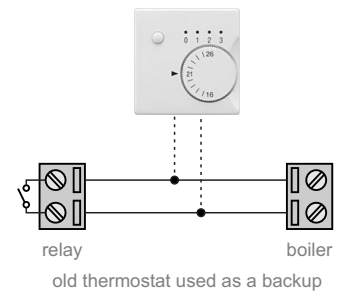
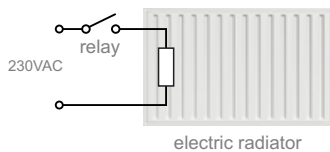
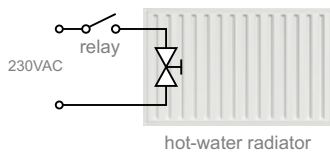
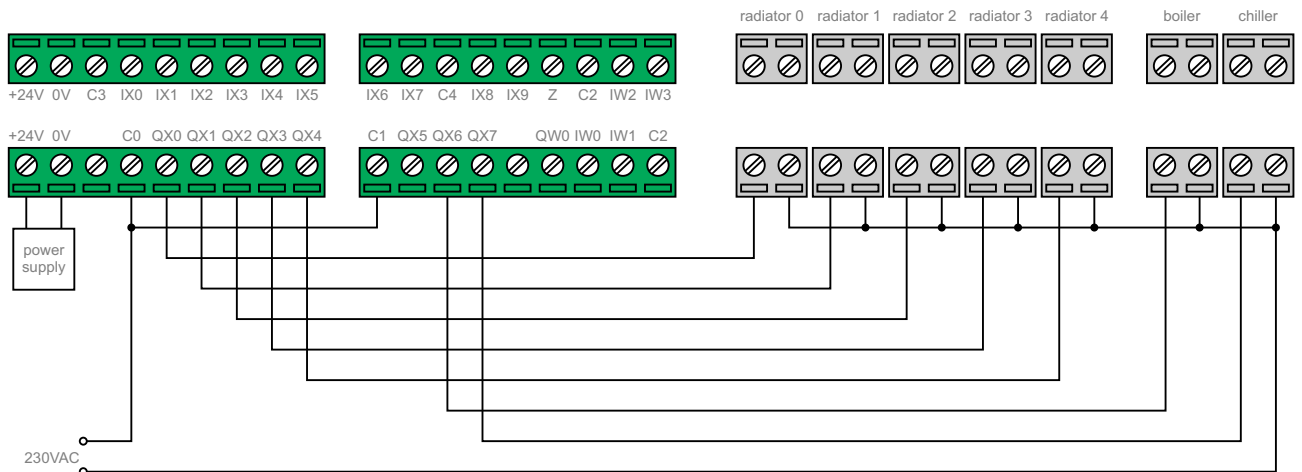

Features

- smartphone connection
- alarm
- HVAC
- timetable
- automation
- scene link
- internet connection

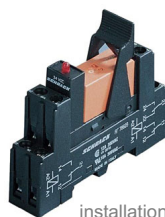

installation relay

Internal relay is used for valves, other loads are recommended to use an additional 16A installation relay.

IEX-2 © HIQ □ CE

- Relay outputs:
- Communication:
- Power supply:
- Ingress protection:
- Operating temperature:
- Storage temperature:
- Relative humidity:
- Mounting:
- Dimensions:
- Weight:
- Standards:

- 3A/250V resistive load only
- Ethernet 100M
- 24V/50mA
- IP20
- 0..45°C
- 20..75°C
- 0..95% n/c
- DIN rail
- 106x108x58mm
- 360g
- EN 61000-6-2, EN 61000-6-3,
- EN 61131-1, EN 61131-2,
- EN 61000-3-2, EN 61000-3-3

LC-10-IQ light controller

10 relay outputs

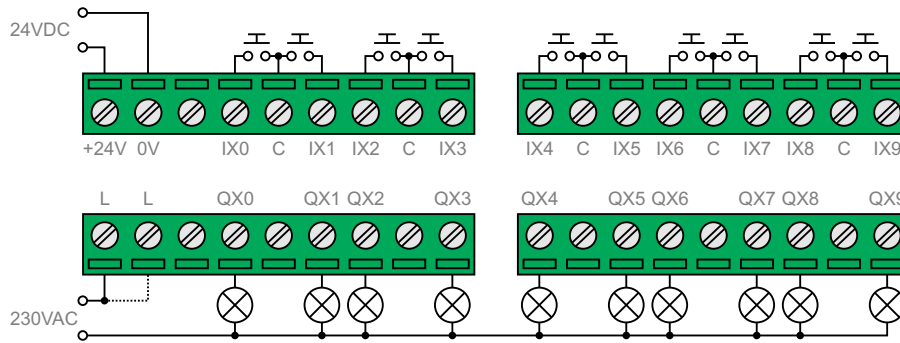

When total output power is 2kW or more, connect mains power supply to both L terminals.



Mounting: 35mm DIN rail 6M

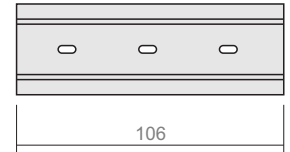

Output mode

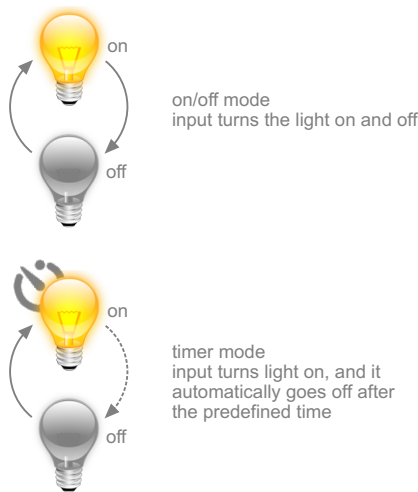

Features

8A

output relays are rated 8A, for a more load use external installation relay or contactor



power outage:
<10min - lights come back
>10min - lights will stay off

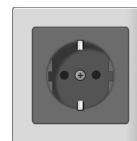

managed socket for devices such as floor lamp, table fan, dehumidifier, electric mosquito repellent, hi-fi system... a distinct color is recommended

Input mode



Input mode defines how input affect the output. Basic functions are handled internally by light controller, night mode and ready light are handled with home controller.

IEX-2 © HIQ □ CE

Output power per relay:
 - incandescent / halogen 230V 800W
 - halogen 12V with transformer 400W
 - fluorescent with electronic ballast 400W
 - parallel compensated fluo lamps 250W/30uF
 - LED with transformer or compact 400W
 Total output power (all relays): 4000W
 Maximum input cable length: 50m
 Power supply: 24V/120mA
 Ingress protection: IP20
 Operating temperature: 0..45°C
 Storage temperature: -20..75°C
 Relative humidity: 0..95% n/c
 Dimensions: 106x108x58mm
 Weight: 250g
 Standards: EN 61000-6-2
 EN 61000-6-3
 EN 60730-1

LD-V4-IQ LED dimmer

4-channel constant voltage dimmer for LED stripes

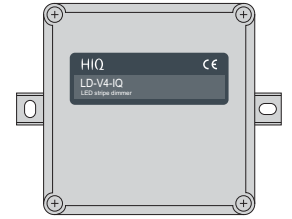

Mounting in-field, junction box or drywall

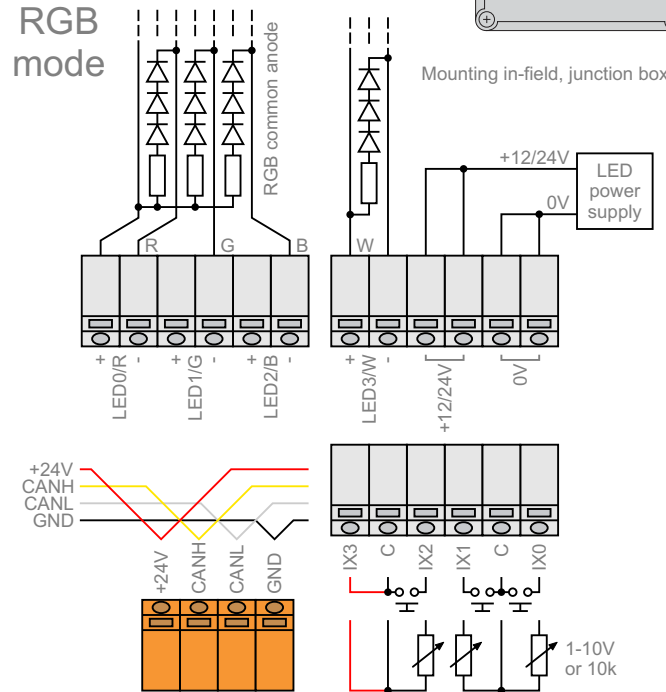
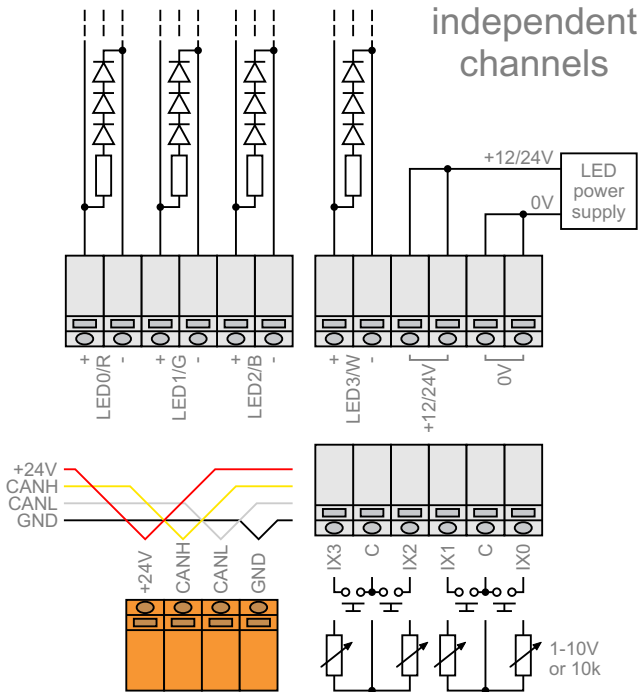

Features



button or potentiometer input:
- autodetect input mode
- mixed controls possible
- potentiometer auto-range



exponential output curve:
- more natural feel
- lowest level is 0.025%
- smooth output transition

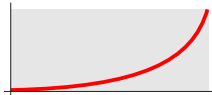

500Hz

high frequency PWM:
- no flickering
- avoid headache
- reduce eye-strain



power outage:
<10min - lights come back
>10min - lights will stay off

output protection:
- overcurrent
- overvoltage
- undervoltage
- watch-dog



maximum current	
output	supply
1x10A	1x10A
2x10A	2x10A
3x6.7A	2x10A
4x5A	2x10A

Operation

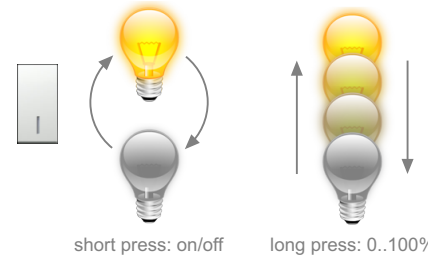

IEX-2 © HIQ □ CE

LED power supply: 12/24V (10..28V)
Total output power: 240W at 12V
480W at 24V
10A
Max current per terminal: 10A
PWM frequency: 500Hz
Output resolution: 12-bit
Power supply: 24V/25mA
Galvanic separation: supply/outputs
Operating temperature: 0..45°C
Storage temperature: -20..75°C
Relative humidity: 0..95% n/c
Dimensions: 108x86x46mm
Weight: 160g
Standards: EN 61000-6-1
EN 61000-6-3
EN 60669

LD-P4-IQ universal dimmer

4-channel dimmer with a separate power driver

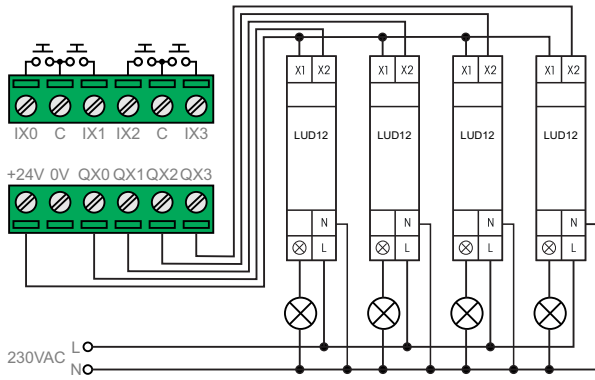
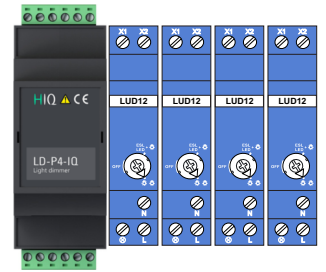

Standard connection with four independent power drivers

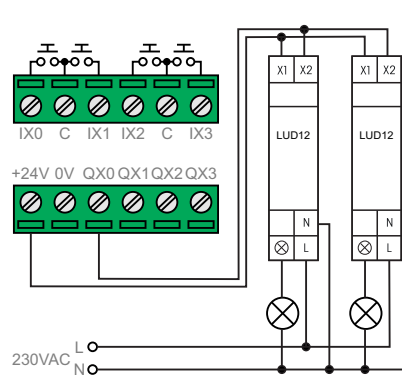

Power increased with a parallel connection of drivers

Mounting: 35mm DIN rail 2M + 4x1M

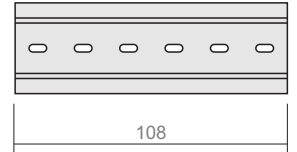

Features



RGB mode
hue, saturation, brightness
instead of individual RGB



white temperature mode
adjust hue in range from
warm white to cold white

button or potentiometer input:
- autodetect input mode
- mixed controls possible
- potentiometer auto-range

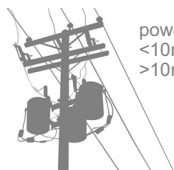

power outage:
<10min - lights come back
>10min - lights will stay off



- 400W power MOSFET
- automatic load detection
- low noise zero switching
- electronic overload protection
- overtemperature shutdown

Operation

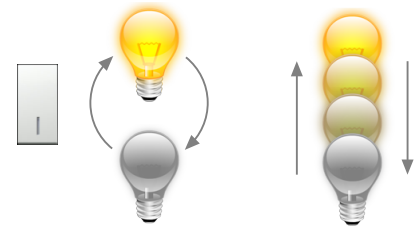

short press: on/off

long press: 0..100%

Driver rotary switch

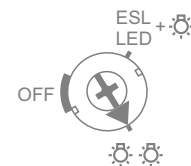

switch must
be adjusted to
indicated
position

Output options



incandescent/halogen



compact fluorescent



compact LED E27/E14



IEX-2 © HIQ □ CE

Lamp power supply:	230V
Output power per driver:	100W
Drivers per output channel:	unlimited
Driver control signal:	PWM 100Hz 24V
Power supply:	24V/25mA
Galvanic separation:	supply/outputs
Operating temperature:	0..45°C
Storage temperature:	-20..75°C
Relative humidity:	0..95% n/c
Dimensions:	36x108x58mm
Weight:	80g
Standards:	EN 61000-6-1 EN 61000-6-3 EN 60669

LD-D8-IQ DALI dimmer

8-channel dimmer for DALI ballasts

Features

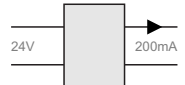
- 8x  control 8 independent groups
- 64x  drive up to 64 ballasts
-  internal DALI current source, no additional power needed

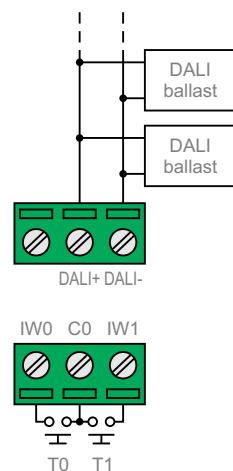

Operation

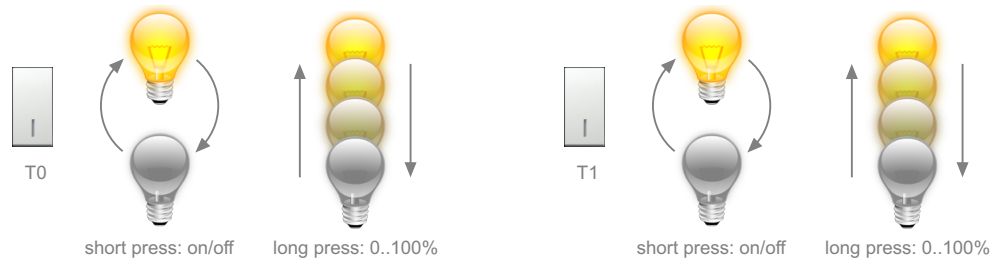

Groups 3 to 8 doesn't have physical input, so they can't be controlled directly, only as a scene or with a phone.

Ballast configuration



Organize your ballasts into groups with address 1 to 8. DALI dimmer master can't control individual ballasts.

Output options



IEX-2 © HIQ □ CE

- | | |
|------------------------|------------------------------|
| Digital inputs: | internal pull-up 12V, 2mA |
| DALI output: | 64 ballasts/200mA max. |
| Power supply: | 24V/120mA |
| Galvanic separation: | none (DALI must be SELV) |
| Ingress protection: | IP20 |
| Operating temperature: | 0..45°C |
| Storage temperature: | -20..75°C |
| Relative humidity: | 0..95% n/c |
| Dimensions: | 36x108x58mm |
| Weight: | 80g |
| Standards: | EN 61000-6-2
EN 61000-6-3 |

BC-5-IQ blinds controller

5-channel blinds position controller

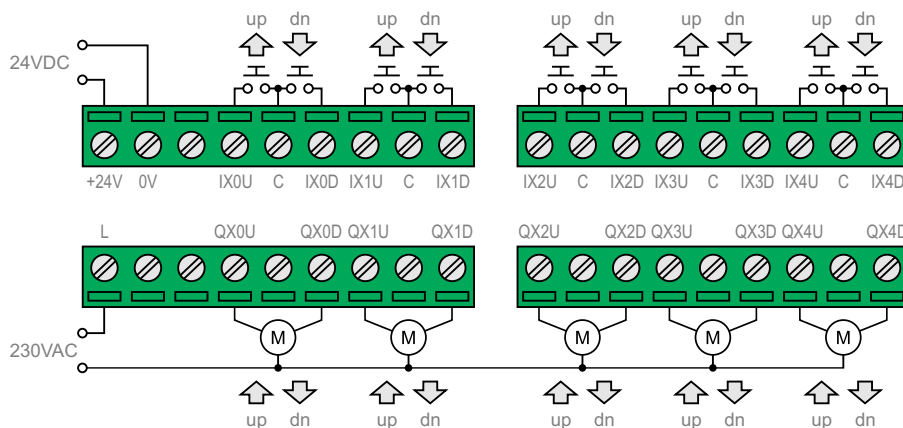

Mounting: 35mm DIN rail 6M

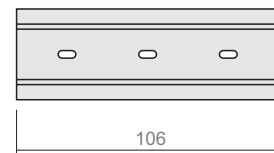

Features

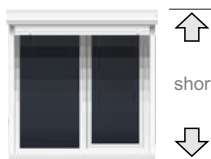

short press: move up/down



short press while moving: stop at the position

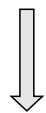

long press: stop after released



short press: move to intermediate position



automatic position related to scene



up and down button



automatic correction at boundary position

Travel time adjustment:

1. Adjust top and bottom limit switch.
2. Use stopwatch to measure travel time in both directions.
3. Mark a position on the window (e.g. 75%), then move blinds a few times up and down, without reaching the top or bottom. If the desired position shifts up, increase down time (or decrease up time) and check again. Repeat procedure until the positioning is precise enough.

IEX-2 © HIQ

Output power per relay:	200W
Total output power (all relays):	2000W
Maximum input cable length:	50m
Power supply:	24V/60mA
Ingress protection:	IP20
Operating temperature:	0..45°C
Storage temperature:	-20..75°C
Relative humidity:	0..95% n/c
Dimensions:	106x108x58mm
Weight:	250g
Standards:	EN 61000-6-2 EN 61000-6-3 EN 60730-1

SC-4-IQ scene controller

4-button universal scene controller

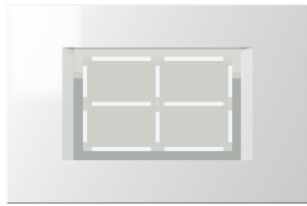

SC-4T-IQ

- 4 configurable touch buttons
- IR receiver + haptic feedback

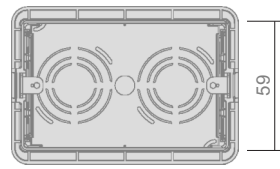
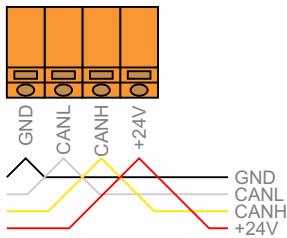

mounting: rectangular box 3M

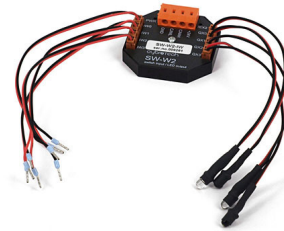

SC-4S-IQ

- 4 button inputs and 4 LED indicators
- connect to any classic button system
- extra-small size fits into any mounting

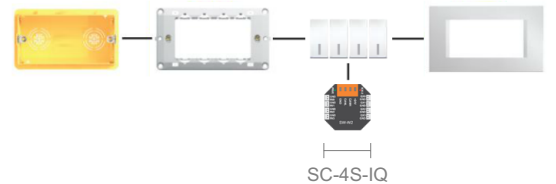
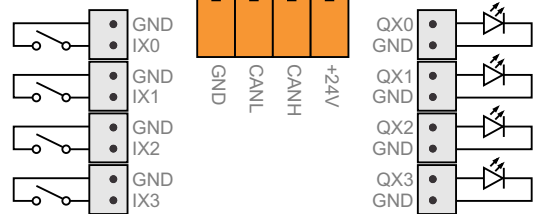

Panel layout (SC-4T-IQ)

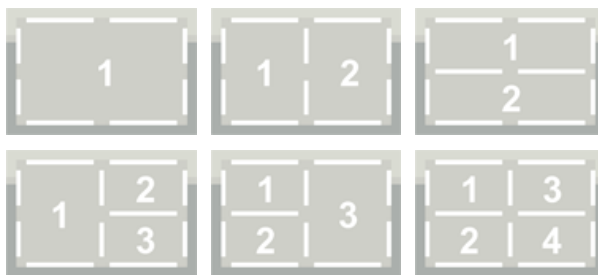

Button action



Inverse scene

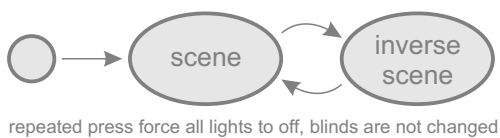

Memorize scene



Remote controller

- 0** set scene 0 (code 1152)
- 1** set scene 1 (code 1153)
- 2** set scene 2 (code 1154)
- ...
- 9** set scene 9 (code 1161)
- set scene 10 (code 1162)
- ...
- set scene 31 (code 1183)

IEX-2 © HIQ □ CE

- IR remote receiver: RC5 36kHz
- Power supply: 24V/25mA (SC-4T), 24V/35mA (SC-4S)
- Ingress protection: IP20
- Operating temperature: 0..45°C
- Storage temperature: -20..75°C
- Relative humidity: 0..95% n/c
- Mounting: rectangular box 3M (SC-4T), any installation box (SC-4S)
- Dimensions: 122x80x23mm (SC-4T), 49x49x7mm (SC-4S)
- Weight: 80g (SC-4T), 20g (SC-4S)
- Standards: EN 61000-6-2, EN 61000-6-3

TH-1-IQ thermostat

simple electronic thermostat

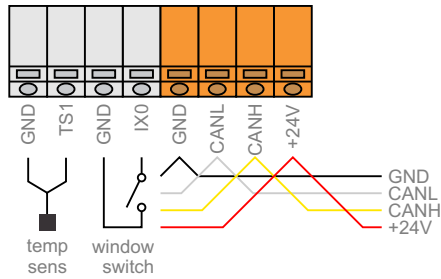

TH-1M-IQ
mechanic buttons







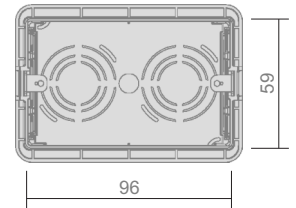



TH-1T-IQ
touch buttons

Mounting: rectangular box 3M



Features







-  on/off
-  setpoint
-  fan control
-  fan max
maximum output for a limited time
-  secondary setpoint when thermostat is off
-  manual measurement correction
-  window switch
shut down heating when window is open
-  night mode
attenuate display during the night

Temperature sensor





Remote measurement should be handled by plc program

Fan options

-  fan speed 1
-  fan speed 2
-  fan speed 3
-  fan speed automatic 1 or 2
-  fan speed automatic 1, 2 or 3
-  maximum output for a limited time

Display when on

-  measured temperature
-  setpoint temperature
-  fan speed

Display when off

-  off
-  dashes
-  temperature

IEX-2 © HIQ □ CE

Window switch input:	internal pull-up 12V, 2mA
Temperature measurement:	internal and external
Measurement range:	0..45°C
Default offset:	-2.5°C
Power supply:	24V/15mA
Ingress protection:	IP20
Operating temperature:	0..45°C
Storage temperature:	-20..75°C
Relative humidity:	0..95% n/c
Mounting:	rectangular flush box
Dimensions:	122x80x23mm
Weight:	80g
Standards:	EN 61000-6-2 EN 61000-6-3

TH-2-IQ thermostat







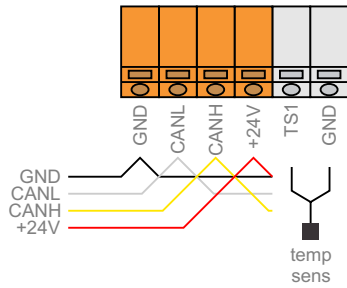

blind electronic thermostat







Mounting: on wall



Features

-  on/off
-  setpoint
-  fan control
-  fan max
maximum output for a limited time
-  precise temperature measurement
-  manual measurement correction
-  secondary setpoint when thermostat is off
-  humidity meter

Signalisation

-  device not addressed
-  device selected
-  setpoint change up
-  setpoint change down

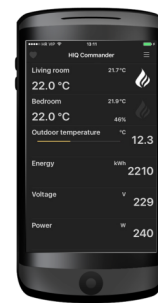

all functions handled by a mobile phone

Temperature sensor



Remote measurement should be handled by plc program

IEX-2 © HIQ □ CE

Temperature measurement:	internal and external
Temperature range:	0..45°C
Default offset:	-1.4°C
Humidity range:	0..100%rh
Power supply:	24V/10mA
Ingress protection:	IP20
Operating temperature:	0..45°C
Storage temperature:	-20..75°C
Relative humidity:	0..95% n/c
Mounting:	wall surface
Dimensions:	71x71x27mm
Weight:	50g
Standards:	EN 61000-6-2 EN 61000-6-3

TH-3-IQ thermostat

thermostat with display and configurable buttons

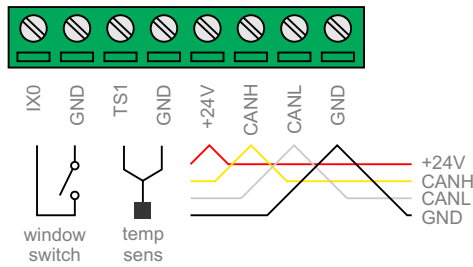
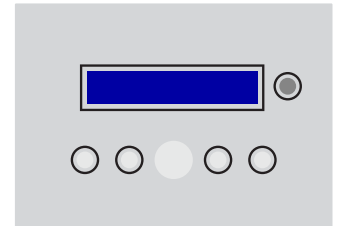

Mounting: regular 60mm junction box



Features

- on/off
- setpoint
- fan control
- fan max
maximum output for a limited time
- secondary setpoint when thermostat is off
- manual measurement correction
- window switch
shut down heating when window is open
- night mode
attenuate display during the night
- humidity meter

Configuration

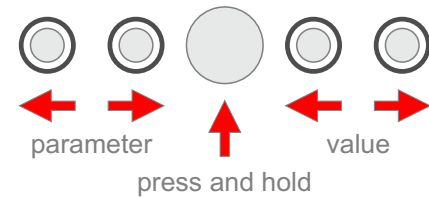

- on/off
- setpoint
- fan speed
- fan max
- scene

Features

- massive aluminium body
- glass power plate
- white blue alphanumeric display
- mechanical buttons with a click
- button function fully configurable
- IR reciver

Temperature sensor



Remote measurement should be handled by plc program

IEX-2 © HIQ □ CE

Temperature measurement:	internal and external
Measurement range:	0..45°C
Default offset:	-2.0°C
Power supply:	24V/25mA
Ingress protection:	IP20
Operating temperature:	0..45°C
Storage temperature:	-20..75°C
Relative humidity:	0..95% n/c
Mounting:	wall surface
Dimensions:	136x96x36mm
Weight:	450g
Standards:	EN 61000-6-2 EN 61000-6-3

FC-1-IQ fan-coil actuator

3-speed fan coil actuator

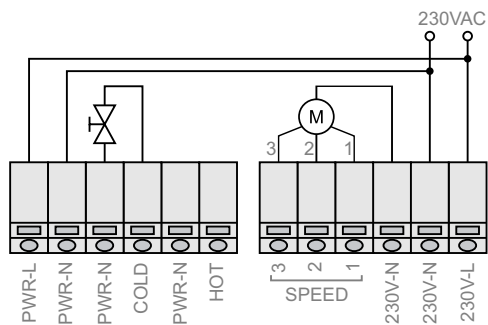
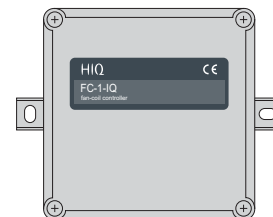

Mounting: inside fan-coil

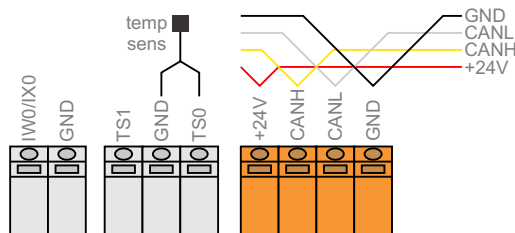
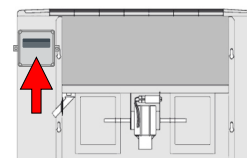

- fan coil
- 2-pipe system
 - electromechanical valve
 - 3-speed fan
 - both heating and cooling

Features

simple
no adjustments, no jumpers or DIP switches, configuration is completely performed on PC

flexible
can be used with a wide range of home, office and industrial convectors

fallback mode
device continue operation even in case that communication is broken

IEX-2 © HIQ □ CE

Relay outputs:	3A/250V
Temperature measurement:	external sensor ES or ES-A
Power supply:	24V/45mA
Operating temperature:	0..45°C
Storage temperature:	-20..75°C
Relative humidity:	0..95% n/c
Mounting:	inside the fan coil unit
Dimensions:	108x86x46mm
Weight:	150g
Standards:	EN 61000-6-2 EN 61000-6-3 EN 60730-1

SDM-120C power meter

voltage, power, relative power and energy meter

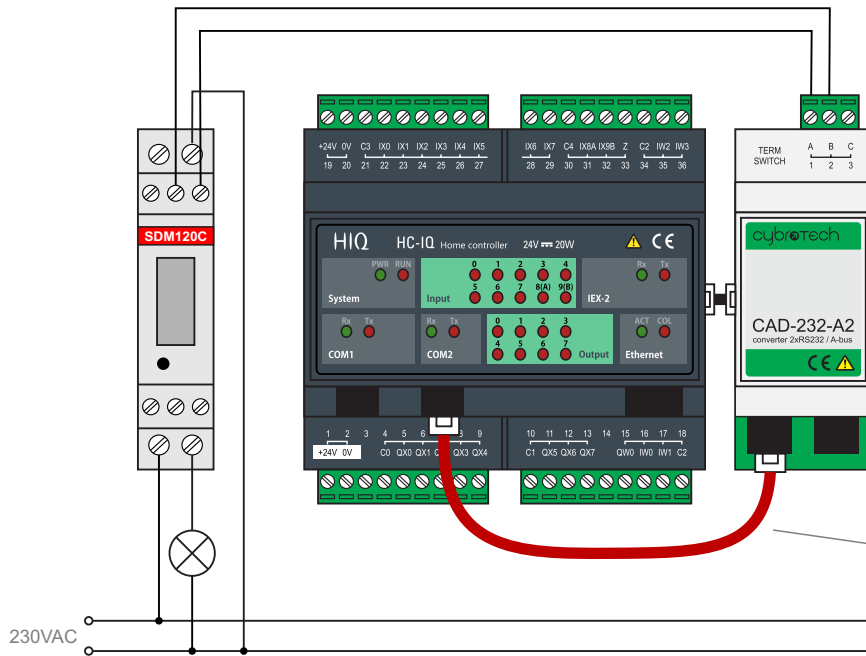
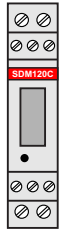

Mounting: 35mm DIN rail 1M + 2M



SDM120C

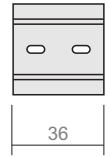

CAD-232-A2

Note: CAD-232-P0 communication cable is delivered together with converter.

SDM-120C
power meter

CAD-232-A2
RS232/485 converter

IEX-2 © HIQ □ CE

Nominal voltage:	230VAC, 110VAC
Voltage range:	77..300VAC
Maximum current:	45A
Operational frequency:	50..60Hz
Power consumption:	2W
Communication setup:	2400 8e1
Modbus address:	1
Communication cable:	CAD-232-P0
Ingress protection:	IP51
Operating temperature:	-25..55°C
Storage temperature:	-30..70°C
Relative humidity:	85%
Mounting:	DIN rail
Dimensions:	119x17.5x62mm
Weight:	85g
Standards:	IEC 62053-21

IR-580-IQ and other sensors

motion sensor, door sensor, light sensor



Motion sensor

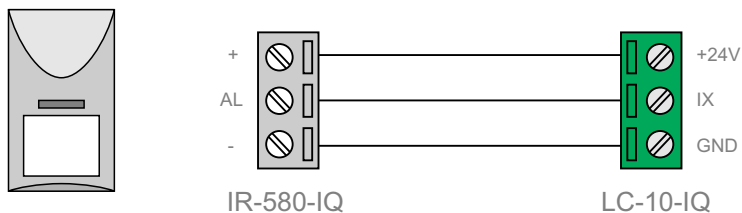

Motion sensor is mounted above or lateral to room entrance. People entering the room must intersect sensor beams. At the moment when closing the door, person should be in the area of maximum sensitivity.

Door sensor



Door sensor is mounted on the knob side, usually about 20cm from the top. Magnet goes into the door, contact goes into the doorpost.

Sensors are connected to spare LC-10-IQ inputs. Input type must be configured as sensor input.

Light sensor

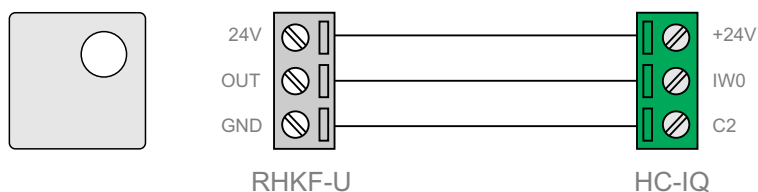

Light sensor is mounted on top of an outside looking window. Best option is west or south side.

For a room with more than one entrance, door sensors are connected in series (sensor is closed when door is closed), and motion sensors are connected in parallel.

Mounting

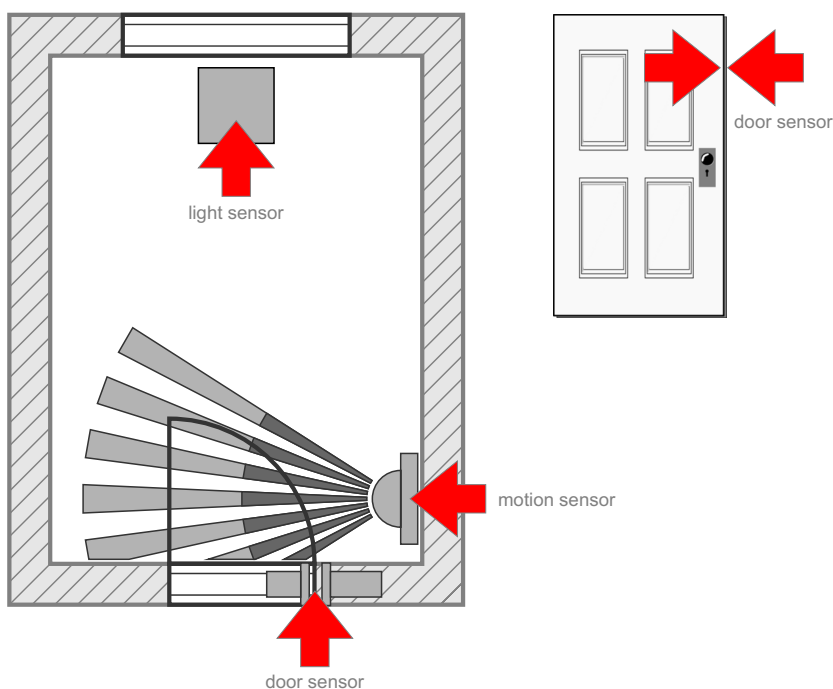

IEX-2 © HIQ □ CE

Door sensor	-
Switch type:	reed switch, normally open
Dimensions:	25x7mm
Weight:	12g
Motion sensor	
Output type:	NPN o.c. 75mA
Power supply:	24V 10mA
Operating temperature:	20..50°C
Storage temperature:	-20..75°C
Dimensions:	100x60x42mm
Weight:	85g
Light sensor	
Output type:	0..10V
Power supply:	24V 80mA
Operating temperature:	0..50°C
Storage temperature:	-20..75°C
Dimensions:	85x85x27mm
Weight:	65g

AS-24RA touchless switch

no-contact wall mounting switch

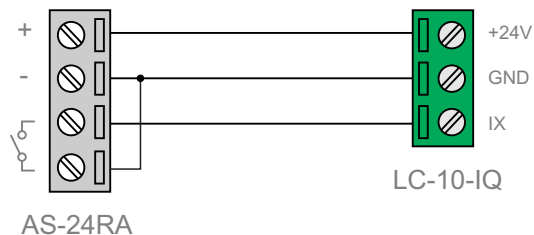

Mounting: regular 68mm junction box

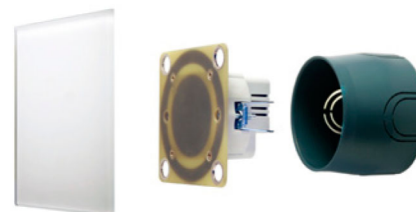

Operation

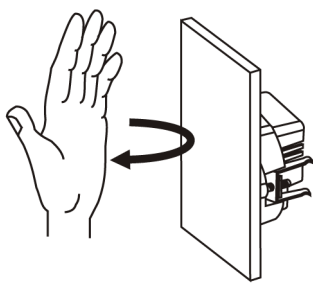

Features

- reliable way to detect a hand through most materials
- countless decorative switchplates
- switchplates attach via magnets and are easily exchanged
- range adjusted with potentiometer
- low power consumption
- excellent noise immunity

Drawing

Dimensions

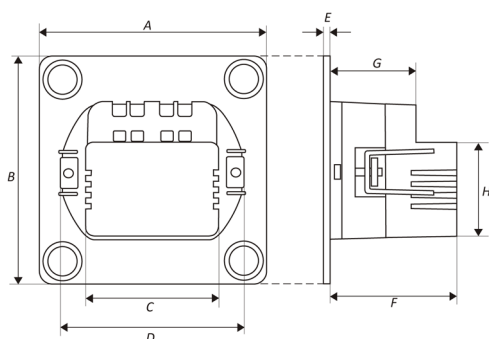

A (width)	70mm
B (height)	70mm
C (back housing width)	40mm
D (back housing width)	59mm
E (plate thickness)	1.6mm
F (depth)	34.4mm
G (depth)	25.5mm
H (back housing height)	28.5mm

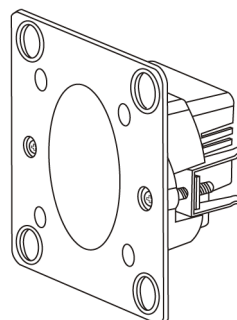

IEX-2 © HIQ □ CE

Switch model:	AS-24RA
Detection distance:	2..10cm adjustable
Detection delay:	200ms
Output type:	NPN o.c. momentary
Power supply:	24V 6mA
Operating temperature:	0..50°C
Storage temperature:	-20..75°C
Weight:	85g

Wiring

Switchboard and field modules

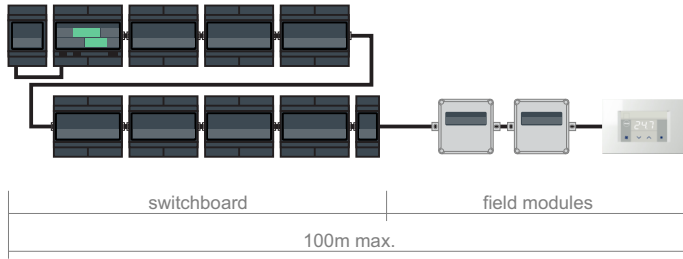

Power supply must be connected to the first (leftmost) device. When devices are connected, autoaddress procedure must be started using HIQ Configurator.

Devices inside switchboard are addressed sequentially, from left to right. Devices outside of switchboard (field modules) are addressed in order of ascending serial numbers - lowest serial number gets the first address, second lowest the second, and so on.

Inside the switchboard, bus is connected with 4x flat cable and RJ9 connectors. Outside the switchboard, bus is connected with a unshielded twisted-pair cable and orange push-wire terminals.

Maximum bus length is 100 meters. Up to that length, bus can be connected with no special rules, branching is allowed. Longer bus (up to 300m) is possible, but cable must be connected in line (no branches/trunks), and last device must be terminated with a 120ohm resistor between CANL and CANH.

Recommended bus cable

unshielded twisted pair 2x2 0.5mm²

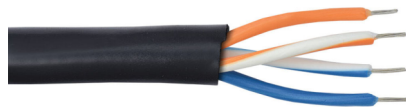

Wire stripping

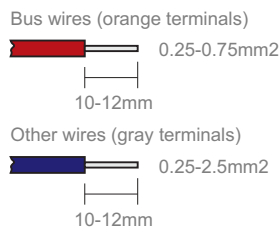

Push-wire handling

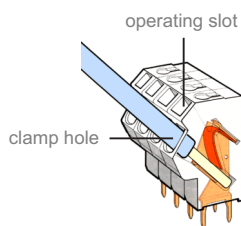

Solid wire insertion

1. Push wire in the clamp hole

Stranded wire insertion

1. Push screwdriver in the operating slot
2. Insert wire in the clamp hole

Solid/stranded wire removal

1. Push screwdriver in the operating slot
2. Remove wire

Bus wiring

1. Take one ingoing and one outgoing wire together, and remove insulation for about 10-12mm.

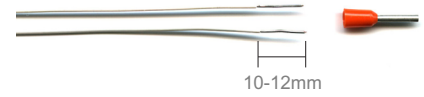

2. Crimp wires together into a ferrule.



3. Wrap wires together for a few centimeters.

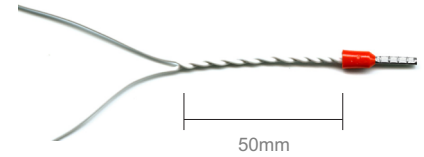

4. Push ferrules into clamps.

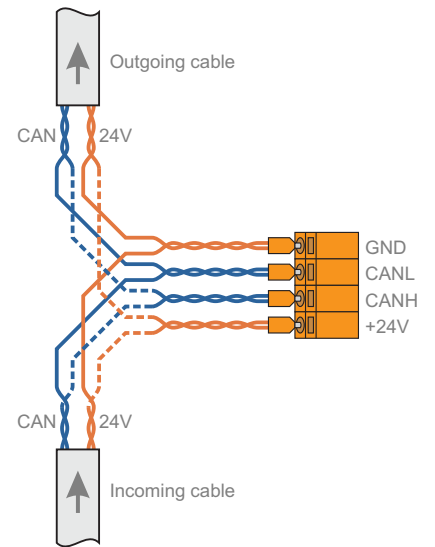

Wire type

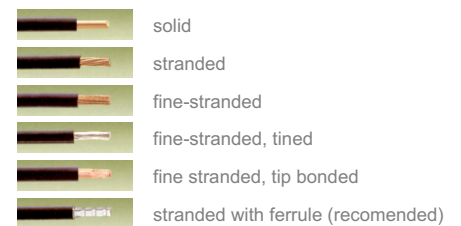

Switch panel

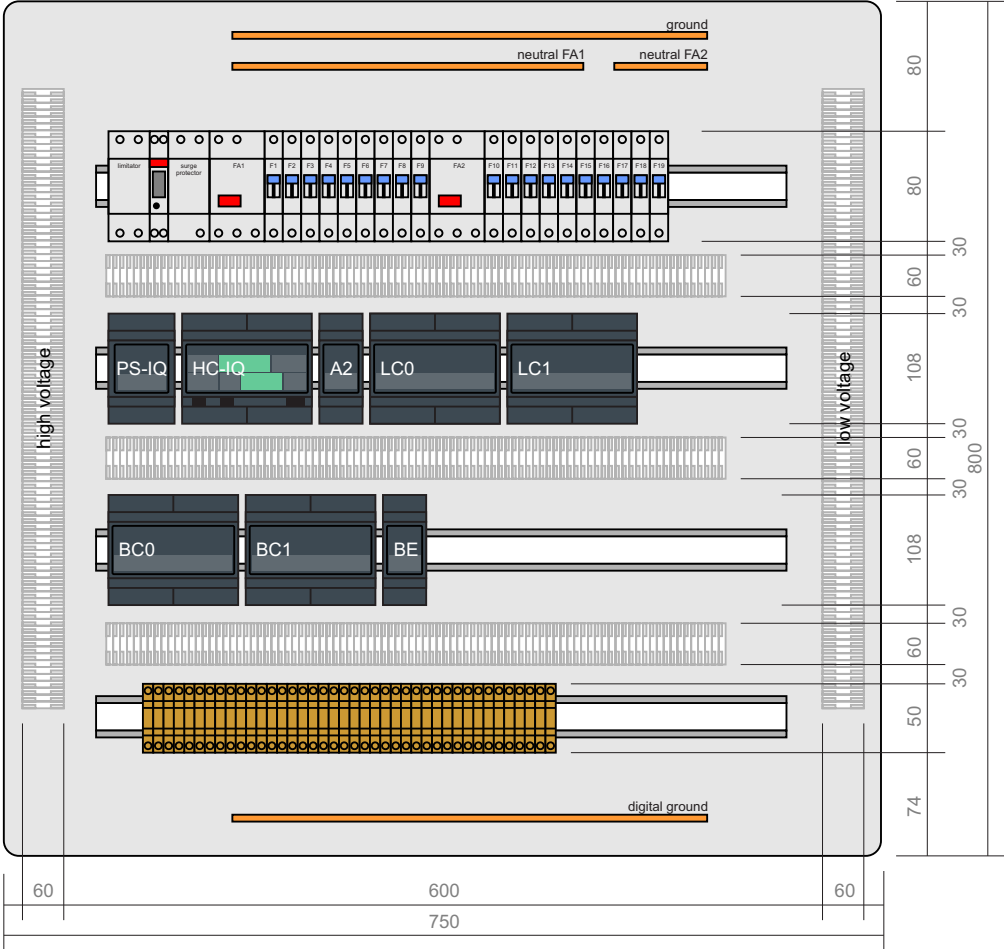

Schematic diagram

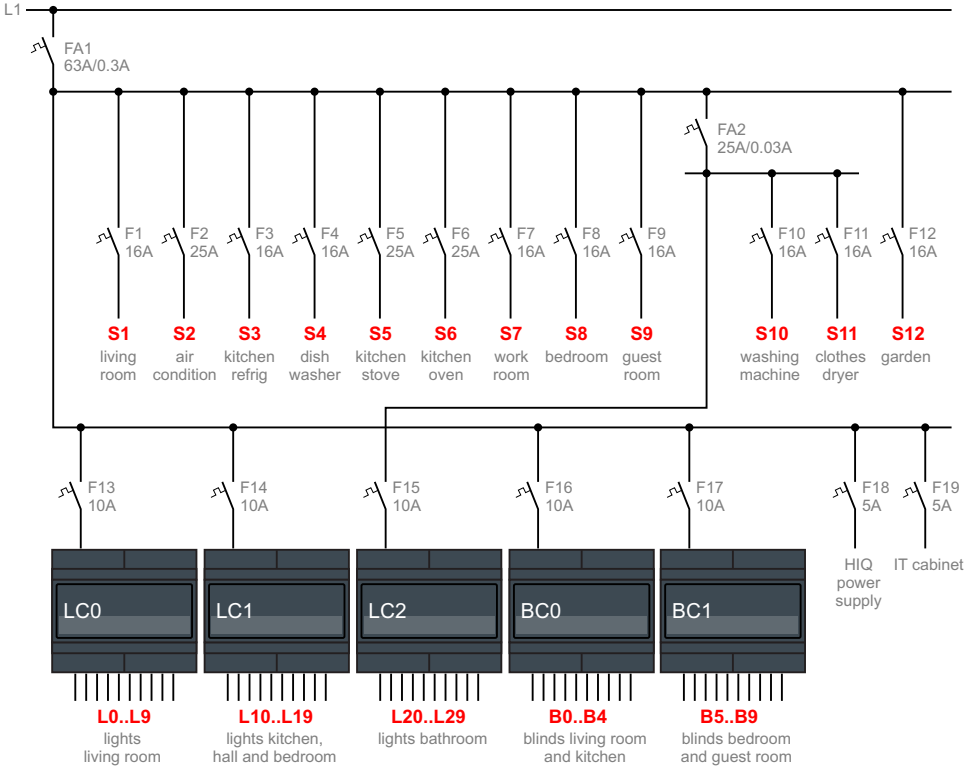

Dimensions

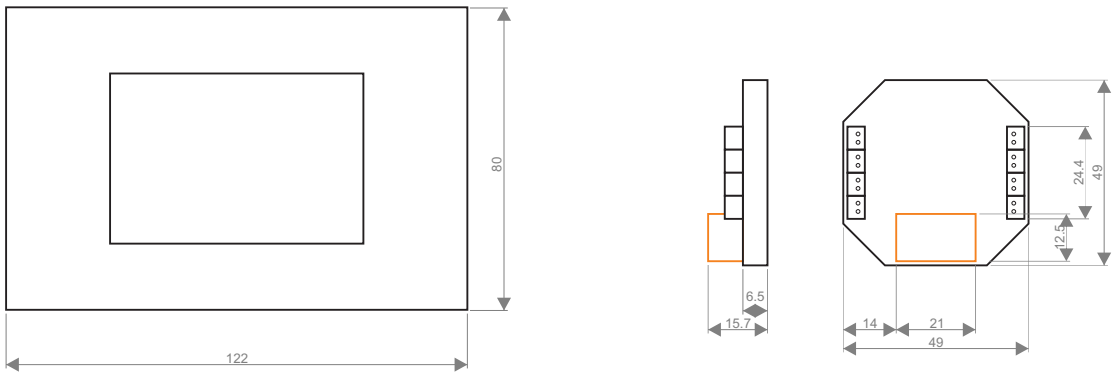
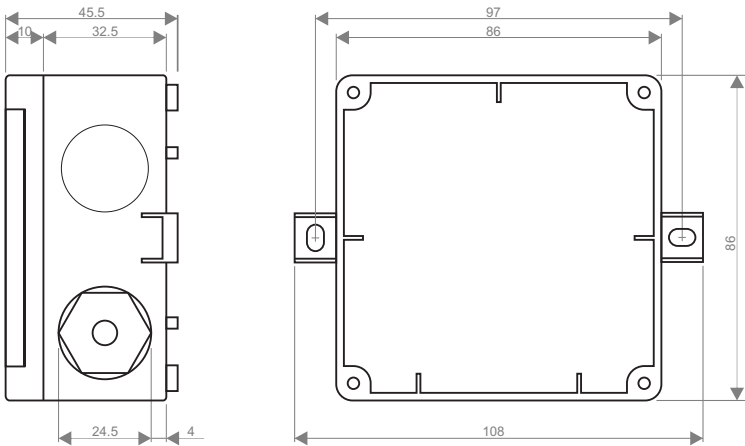
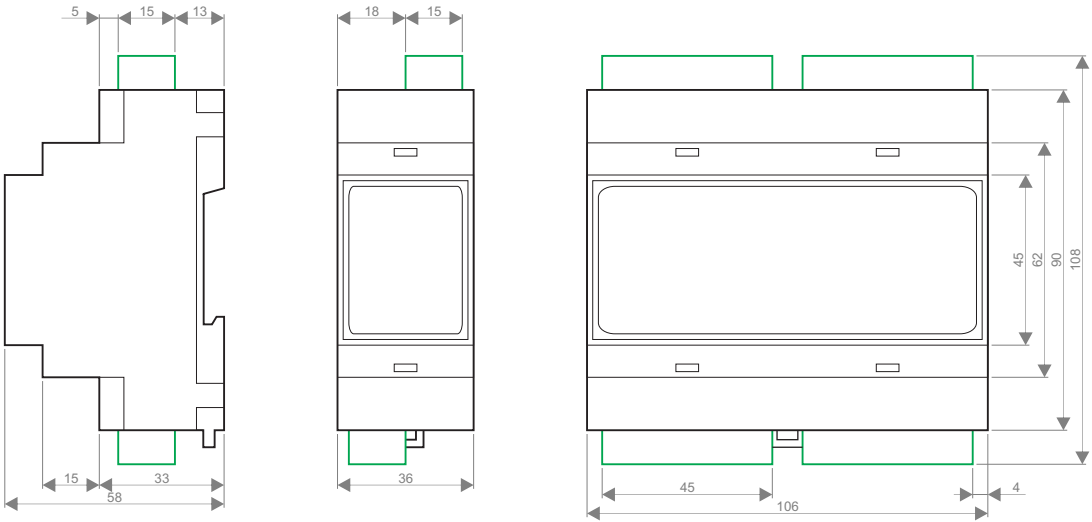

Order code

devices and sensors



LC-10-IQ
light controller
with 10 outputs



LD-P4-IQ
4-channel
universal dimmer
LUD-12
power driver

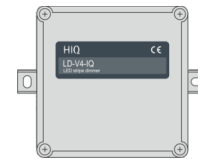

LD-V4-IQ
4-channel
LED strip
dimmer



BC-5-IQ
5-channel
blinds controller



LD-D8-IQ
8-channel
DALI dimmer



SC-4T-IQ
touch screen
scene controller

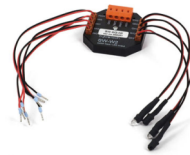

SC-4S-IQ
scene controller for
standard buttons



TH-1T-IQ
thermostat with
touch buttons



TH-2-IQ
blind thermostat



TH-1M-IQ
thermostat with
mechanical buttons

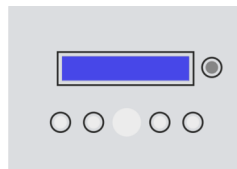

TH-3-IQ
thermostat with
scene buttons



FC-1-IQ
fan-coil
actuator



HC-IQ
home controller



PS-IQ
power supply 24V



BE-PROT
bus adapter +
surge protector



IR-580-IQ
motion sensor



REED-SW
door sensor



RHKF-U
light sensor

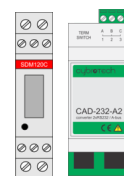

SDM120C
power meter
CAD-232-A2
232/485 converter
(including cable)

Order code

cables and accessories



RE-2
IR remote controller



ES
temperature sensor



ES-A
temperature sensor



CAD-P0
bus cable 2.5cm, RJ9/RJ9
connecting devices in switchboard



CAD-2-BUT
2x mini-button



CAD-P2
bus cable 2m, RJ9/RJ9
connecting rows in switch panel



CAD-232-P0
cable for 232/485 converter



OL30-PW
3M decorative cover



SM11-PW-NT
push button 1M



NM30
mounting frame for
3M rectangular box



SM41-PW-NT
push button 1M
up/down



AS-24RA
touchless switch