

# HIQ Office

User Manual v15 rev 2



OIC Hrpelje 38  
6240 Kozina  
Slovenija/EU  
[info@robotina.si](mailto:info@robotina.si)

## General overview



- for offices and business buildings, new and retrofit
- advanced, easy to use system for best working conditions, comfort and efficiency
- intuitive user interface for every user and SCADA system for central management
- easy setup and integration with any iBMS, HRM, access control and other systems
- local control and automation, energy efficiency and other services through cloud

## Building layout

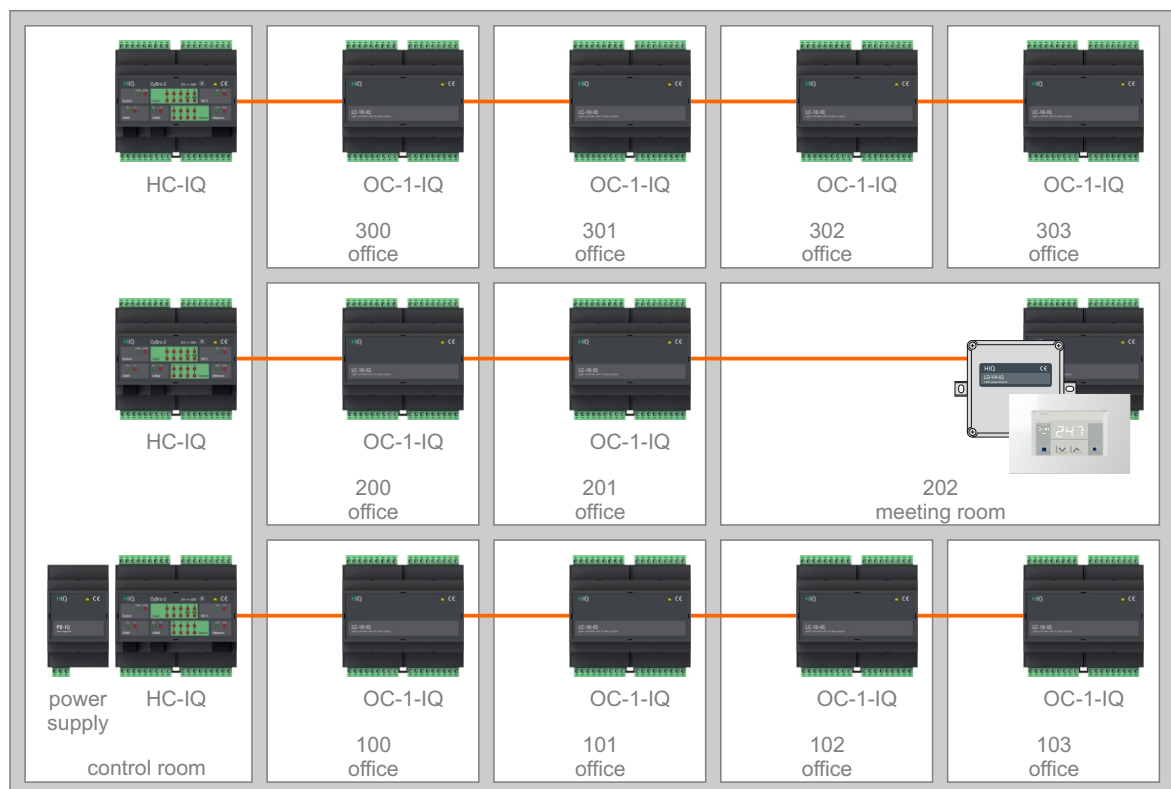

- each master controller (HC-IQ) can handle up to 20 office controllers (OC-1-IQ)
- total number of master controllers in the building is unlimited
- meeting rooms, halls and other may use other HIQ devices (LC/LD/BC/TH/FC)

# System elements



HC-IQ

switch panel



OC-1-IQ

IR-580-IQ

each office



TH-1T-IQ

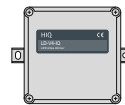

FC-1-IQ

meeting room and halls



cyp

controller program



xml

mini scada

template for office application



OPC Server

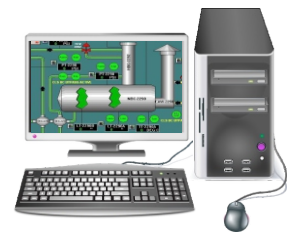

building integration



development



data logger



backup tool

software tools



mini scada



centralized control



pc gadget

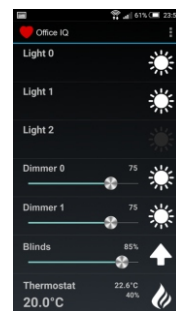

smartphone app

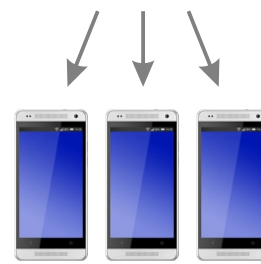

office computers and smartphones

# Connection

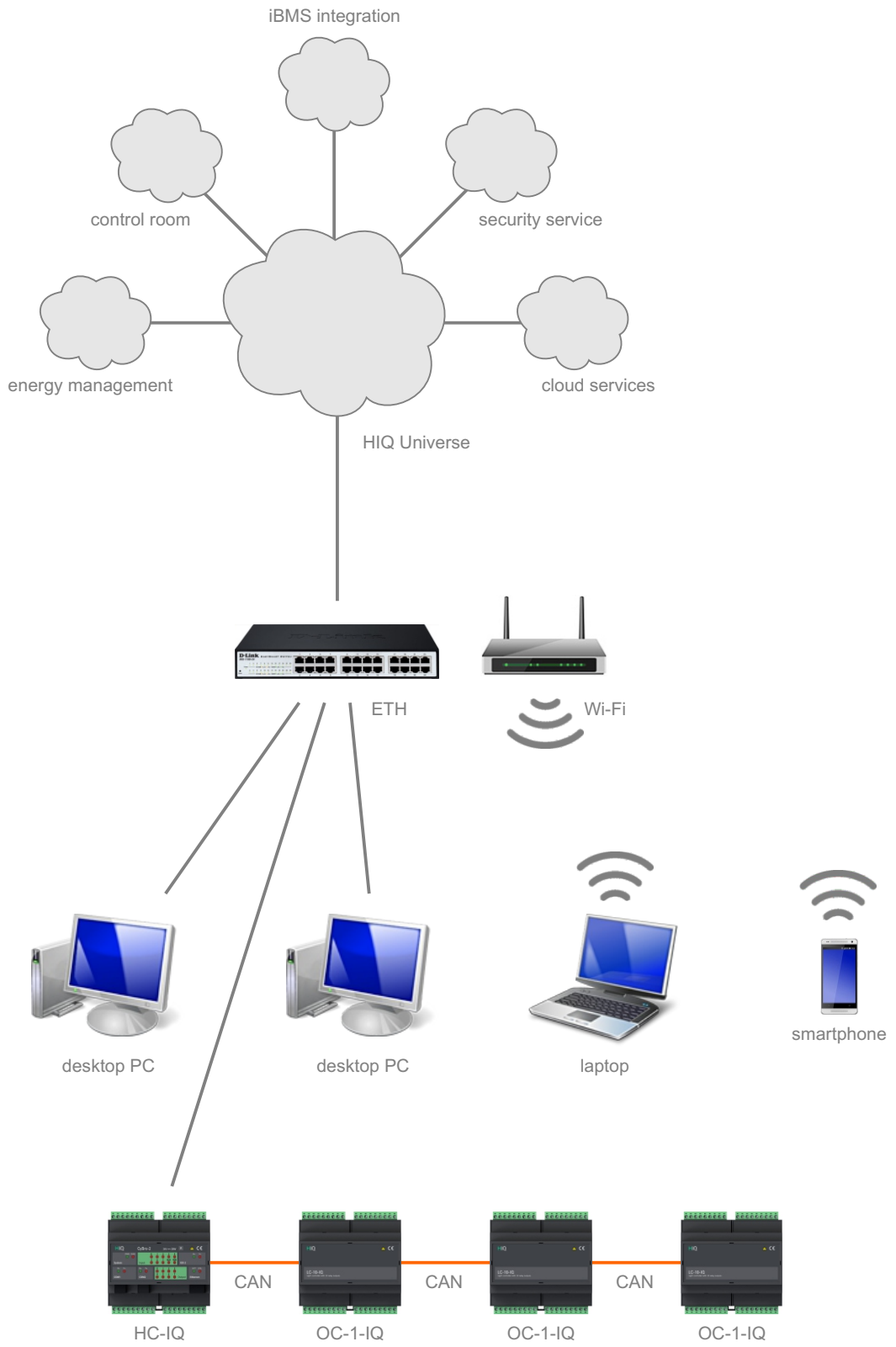

## Office features



on/off lights

3x



dimmable DALI lights

3x

— or —



blinds

1x



heating/cooling regulation

1x



fan speed control

1x



button



smartphone



PC gadget

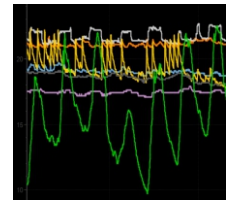

SCADA

office

centralized control

## Control scope

on/off lights



dimmable lights



blinds



heating/cooling



## Control range

office



meeting room



schedules



system limits



## Automatic lights

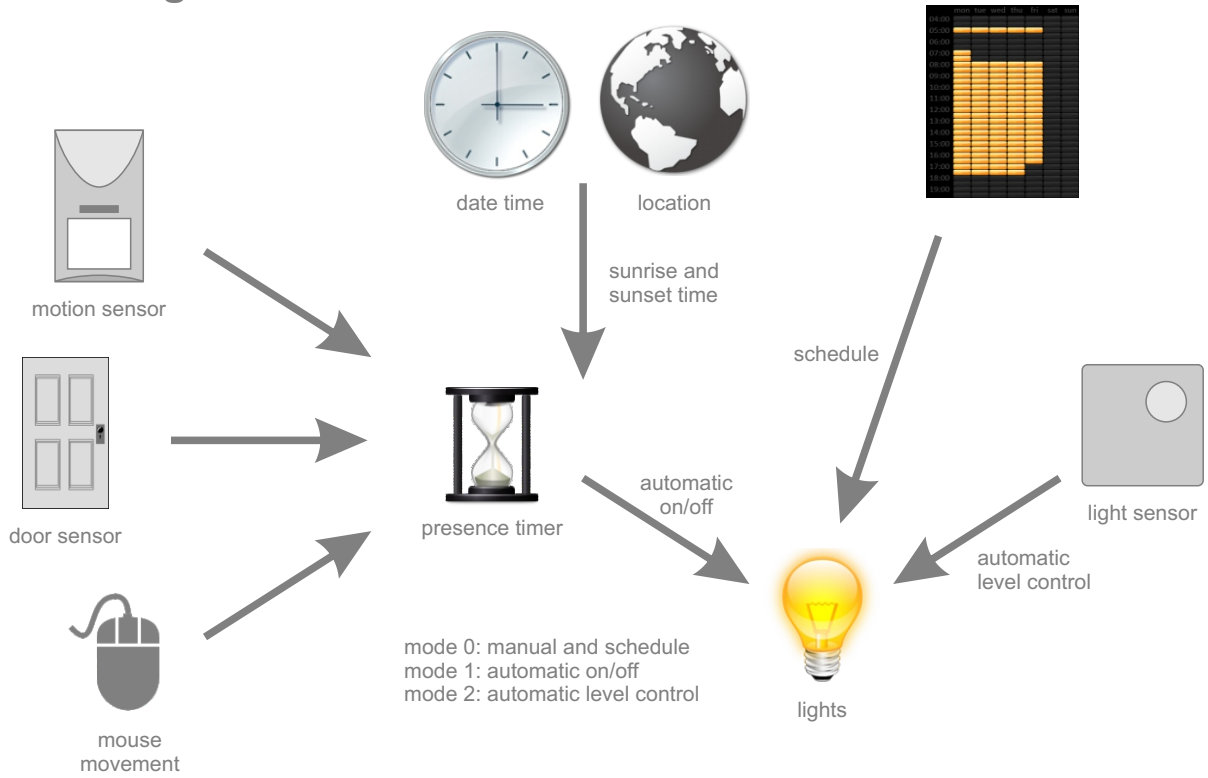

## Heating/cooling

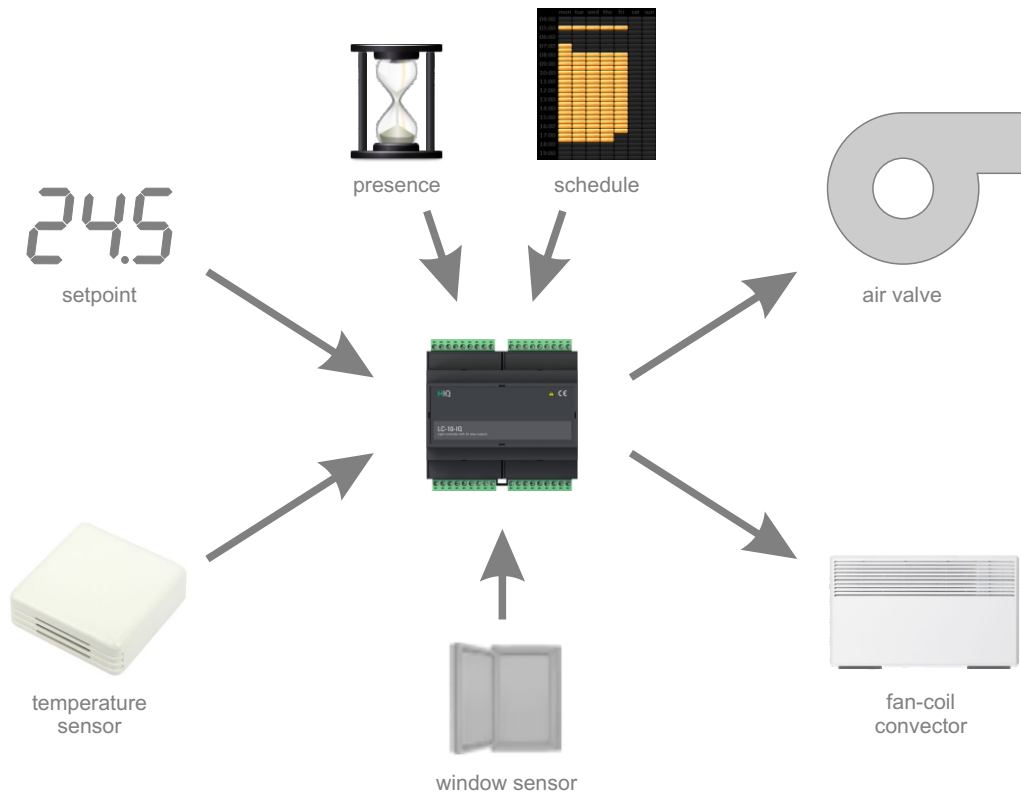

# Wiring

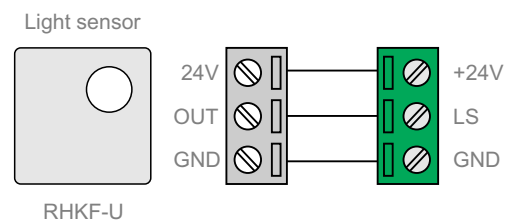
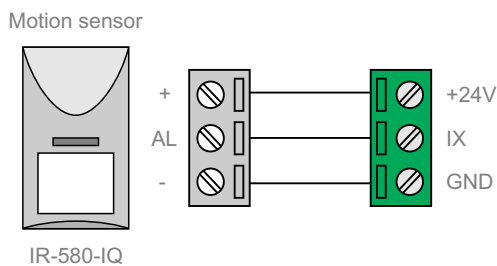
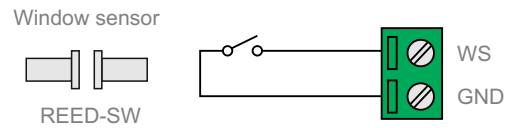
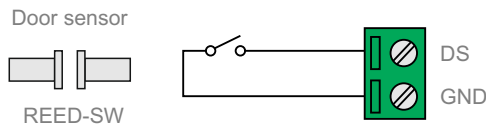
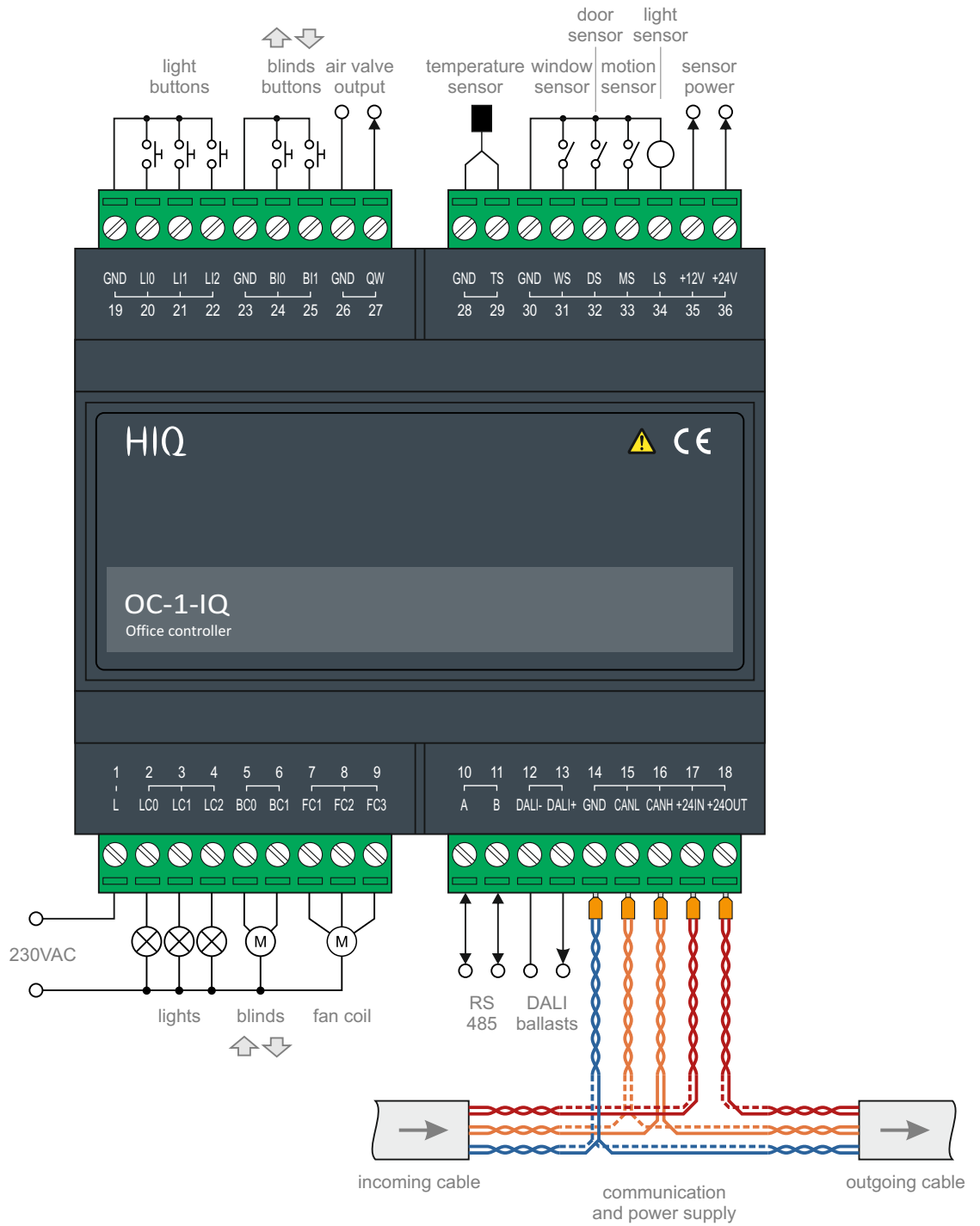

# Technical specifications

HIQ © □ CE

Outputs	.
Lights:	
- LED downlighters	400W per output
- fluorescent with electronic ballast	400W per output
- fluorescent with parallel compensation	200W 30uF per output
- incandescent or halogen 230V	800W per output
Blinds motor:	200W
Fan coil motor:	200W
DALI output:	12 ballasts
Current source:	50mA internal
Ballast configuration:	DALI group address 1, 2 and 3
Galvanic separation:	none (SELV ballast required)
Air valve output:	1..10V 10mA
Galvanic separation:	none
Inputs	
Window switch:	reed contact, normally open
Door sensor:	reed contact, normally open
Motion sensor:	NPN transistor, normally open
Light sensor:	0..10V analog
Temperature sensor:	18B20 2-wire
Sensor power supply:	24V 50mA, 12V 50mA
Button/sensor input:	internal pull-up 12V 2mA
Wire length:	50m
Galvanic separation:	none
General	
Communication bus:	IEX-2 CAN 2.0B
Bus length:	250m
Termination required:	>100m
Termination resistor:	120 Ohm CANL/CANH
Recommended cable:	CAT6 AWG23
Wiring:	1 pair CANL/CANH 1 pair +24V (both wires) 1 pair GND (both wires)
RS485 bus:	custom apps only
Galvanic separation:	none
Nominal power supply:	24V
Power supply range:	18..26V
Current consumption:	120mA without sensors
Operating temperature:	0..45°C
Storage temperature:	-20..75°C 85% rh
Ingress protection:	IP20
Dimensions:	106x108x58mm
Weight:	250g
Standards:	EN 61000-6-2 EN 61000-6-3 EN 60730-1



## Order code



OC-1-IQ  
office controller



HC-IQ  
master controller



PS-IQ  
power supply 24V



BE-PROT  
bus adapter +  
surge protector



IR-580-IQ  
motion sensor



RHKF-U  
light sensor



ES  
temperature sensor



ES-A  
temperature sensor



REED-SW  
door sensor  
window sensor



ES-W  
temperature sensor

HIQ Office is compatible with all HIQ modules, check [www.robotina.com](http://www.robotina.com) for details.